

# Double Bearing Housings ZLG 300

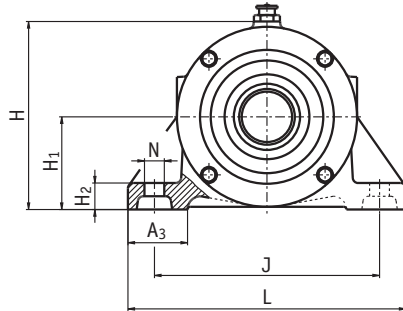

shaft		bearing housing																		
d	d <sub>1</sub>	code number	A	A <sub>1</sub>	A <sub>2</sub>	A <sub>3</sub>	H	H <sub>1</sub>	H <sub>2</sub>	J	J <sub>1</sub>	L	N	W	W <sub>1</sub>	W <sub>2</sub>	B	d <sub>3</sub>		
30	40	ZLG 306	235	30	20	40	100	50	16	130	150	170	15	173,0	140,0	57,0	53,0	-		
														174,5	141,5			35		
														174,5	140,5			-		
35	45	ZLG 307	275	30	20	40	117	60	16	150	175	190	15	197,0	160,0	66,5	60,0	-		
														198,5	161,5			69,0	62,5	40
														198,5	160,5			66,5	60,0	-
40	50	ZLG 308	330	36	26	40	121	60	18	150	225	190	15	257,0	214,0	69,5	65,0	-		
														258,5	215,5			50		
														258,5	214,5			-		
45	55	ZLG 309	370	36	26	45	139	70	20	170	250	210	15	280,5	235,5	78,5	72,5	-		
														282,5	237,5			55		
														282,5	236,5			-		
50	60	ZLG 310	405	40	30	45	142	70	20	170	275	210	15	314,5	265,5	81,0	77,5	-		
														316,5	267,5			60		
														316,5	266,5			-		
55	65	ZLG 311	433	40	30	60	158	80	23	210	300	270	20	336,5	287,5	84,0	79,0	-		
														338,5	289,5			65		
														338,5	288,0			-		
60	70	ZLG 312	479	40	30	60	162	80	23	210	340	270	20	384,0	333,0	84,0	81,5	-		
														385,5	334,5			87,5	85,0	70
														385,5	333,0			84,0	81,5	-
65	75	ZLG 313	503	45	35	60	187	95	25	230	360	290	20	402,0	348,0	88,0	83,5	-		
														404,5	350,5			91,5	87,0	75
														404,5	349,0			88,0	83,5	-

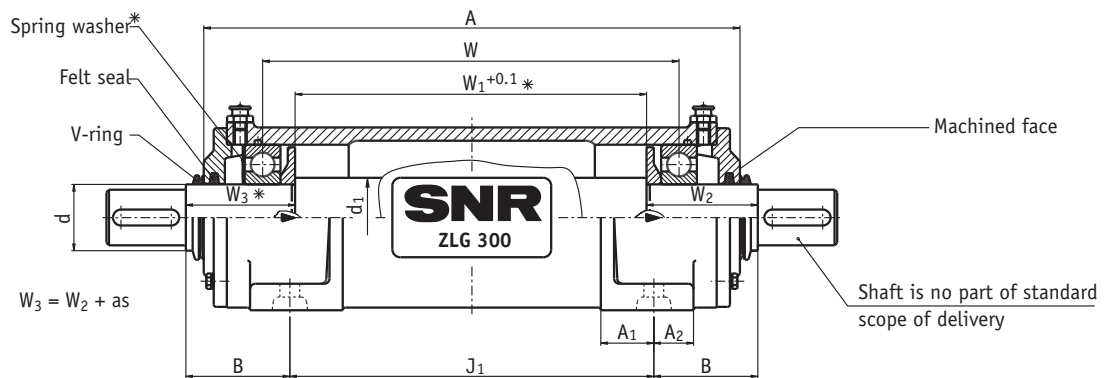

\* The spring washer may not be mounted for alternating axial loads. Dimension W1 is then increased by dimension "as", W3 is then equal to W2.

## Design AA

If you notify us the dimensions of the mating structure for your design, we will be glad to supply you with double or triple bearing housings fully mounted, pre-lubricated and with a corresponding shaft. That means that you have the advantage of getting the complete unit from one supplier only.

p	as	mounting parts		felt ring	V-ring	spring washer	unit designation	housing weight approx. kg
		bearing 1	bearing 2					
-	1,5	6306 C3	6306 C3	FI 7	V-30S	ASG 6306	ZLG 306 AA	8
31	-	NU 306 EG15 C3		FI 8	V-35S	-	ZLG 306 AB	
-	-	NJ 306 EG15 C3		FI 7	V-30S	-	ZLG 306 AC	
-	1,5	6307 C3	6307 C3	FI 8	V-35S	ASG 6307	ZLG 307 AA	10
40	-	NU 307 EG15 C3		FI 9	V-40S	-	ZLG 307 AB	
-	-	NJ 307 EG15 C3		FI 8	V-35S	-	ZLG 307 AC	
-	1,5	6308 C3	6308 C3	FI 9	V-40S	ASG 6308	ZLG 308 AA	12
36,5	-	NU 308 EG15 C3		FI 11	V-50S	-	ZLG 308 AB	
-	-	NJ 308 EG15 C3		FI 9	V-40S	-	ZLG 308 AC	
-	2,0	6309 C3	6309 C3	FI 10	V-45S	ASG 6309	ZLG 309 AA	16
43,5	-	NU 309 EG15 C3		FI 12	V-55S	-	ZLG 309 AB	
-	-	NJ 309 EG15 C3		FI 10	V-45S	-	ZLG 309 AC	
-	2,0	6310 C3	6310 C3	FI 11	V-50S	ASG 6310	ZLG 310 AA	19
43	-	NU 310 EG15 C3		FI 13	V-60S	-	ZLG 310 AB	
-	-	NJ 310 EG15 C3		FI 11	V-50S	-	ZLG 310 AC	
-	2,0	6311 C3	6311 C3	FI 12	V-55S	ASG 6311	ZLG 311 AA	25
45	-	NU 311 EG15 C3		FI 15	V-65S	-	ZLG 311 AB	
-	-	NJ 311 EG15 C3		FI 12	V-55S	-	ZLG 311 AC	
-	1,5	6312 C3	6312 C3	FI 13	V-60S	ASG 6312	ZLG 312 AA	30
46,5	-	NU 312 EG15 C3		FI 16	V-70S	-	ZLG 312 AB	
-	-	NJ 312 EG15 C3		FI 13	V-60S	-	ZLG 312 AC	
-	2,5	6313 C3	6313 C3	FI 15	V-65S	ASG 6313	ZLG 313 AA	33
48	-	NU 313 EG15 C3		FI 17	V-75S	-	ZLG 313 AB	
-	-	NJ 313 EG15 C3		FI 15	V-65S	-	ZLG 313 AC	

# Double Bearing Housings ZLG 300

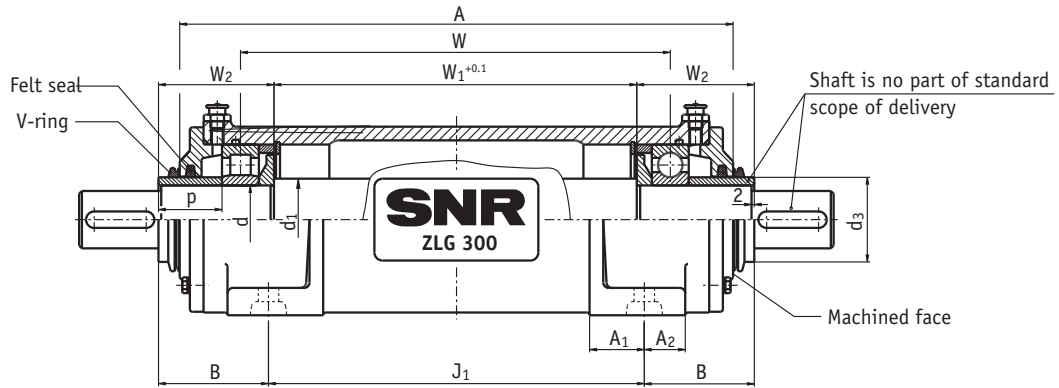

## Design AB

shaft d	dimensions [mm]																		
	bearing housing code number	A	A <sub>1</sub>	A <sub>2</sub>	A <sub>3</sub>	H	H <sub>1</sub>	H <sub>2</sub>	J	J <sub>1</sub>	L	N	W	W <sub>1</sub>	W <sub>2</sub>	B	d <sub>3</sub>		
70	80	ZLG 314	534	45	35	60	190	95	25	230	380	290	20	421,0	364,0	92,5	-	-	
														423,5	366,5				80
														423,5	365,0				-
75	90	ZLG 315	559	45	35	70	200	100	28	260	400	330	20	450,0	389,0	99,0	95,0	-	
														452,5	391,5				90
														452,5	390,0				-
80	95	ZLG 316	585	50	40	70	220	112	30	260	420	330	20	468,0	405,0	104,0	98,0	-	
														470,5	407,5				95
														470,5	406,0				-
85	100	ZLG 317	593	50	40	70	225	112	30	290	440	350	20	478,0	415,0	103,0	92,0	-	
														480,5	417,5				100
														480,5	416,0				-
90	105	ZLG 318	605	55	45	70	230	112	30	290	460	350	20	483,5	418,5	107,0	88,0	-	
														486,5	421,5				110
														486,5	420,0				107,0
95	110	ZLG 319	633	60	50	90	248	125	35	320	480	400	24	508,5	440,5	110,5	92,0	-	
														511,5	443,5				110
														511,5	442,0				110,5
100	115	ZLG 320	673	60	50	80	264	130	40	320	500	400	24	533,0	463,0	118,5	102,0	-	
														536,5	466,5				120
														536,5	465,0				118,5
110	130	ZLG 322	678	70	60	100	296	150	40	380	520	450	26	577,0	504,0	102,5	96,5	-	
														580,5	507,5				130
														580,5	506,0				-
120	140	ZLG 324	705	78	60	115	320	160	40	410	540	500	35	599,5	521,5	107,5	100,0	-	
														602,5	524,5				140
														602,5	523,0				-

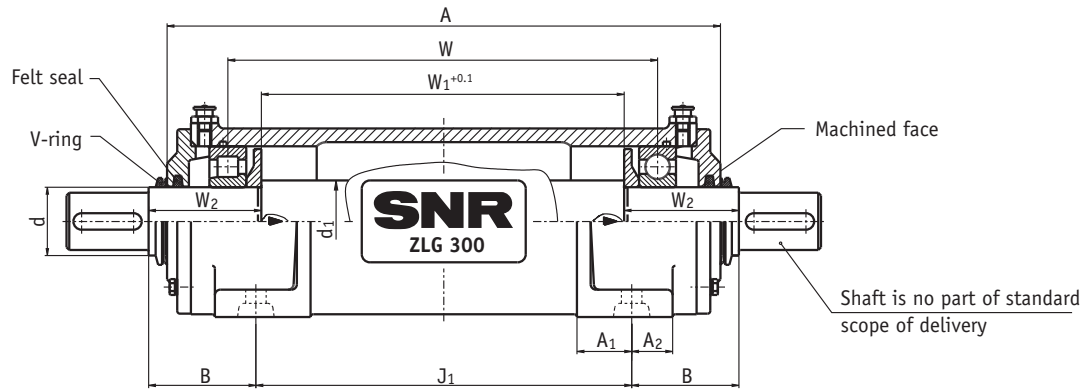

## Design AC

If you notify us the dimensions of the mating structure for your design, we will be glad to supply you with double or triple bearing housings fully mounted, pre-lubricated and with a corresponding shaft. That means that you have the advantage of getting the complete unit from one supplier only.

p	as	mounting parts		felt ring	V-ring	spring washer	unit designation	housing weight approx. kg
		bearing 1	bearing 2					
-	2,5	6314 C3	6314 C3	FI 16	V-70S	ASG 6314	ZLG 314 AA	37
53	-	NU 314 EG15 C3		FI 18	V-80S	-	ZLG 314 AB	
-	-	NJ 314 EG15 C3		FI 16	V-70S	-	ZLG 314 AC	
-	2,5	6315 C3	6315 C3	FI 17	V-75S	ASG 6315	ZLG 315 AA	47
50	-	NU 315 EG15 C3		FI 20	V-90S	-	ZLG 315 AB	
-	-	NJ 315 EG15 C3		FI 17	V-75S	-	ZLG 315 AC	
-	2,5	6316 C3	6316 C3	FI 18	V-80S	ASG 6316	ZLG 316 AA	56
53	-	NU 316 EG15 C3		FI 21	V-95S	-	ZLG 316 AB	
-	-	NJ 316 EG15 C3		FI 18	V-80S	-	ZLG 316 AC	
-	2,5	6317 C3	6317 C3	FI 19	V-85S	ASG 6317	ZLG 317 AA	64
51	-	NU 317 EG15 C3		FI 22	V-100S	-	ZLG 317 AB	
-	-	NJ 317 EG15 C3		FI 19	V-85S	-	ZLG 317 AC	
-	3,0	6318 C3	6318 C3	FI 20	V-90S	ASG 6318	ZLG 318 AA	71
55	-	NU 318 EG15 C3		FI 24	V-110S	-	ZLG 318 AB	
-	-	NJ 318 EG15 C3		FI 20	V-90S	-	ZLG 318 AC	
-	3,0	6319 C3	6319 C3	FI 21	V-95S	ASG 6319	ZLG 319 AA	82
56	-	NU 319 EG15 C3		FI 24	V-110S	-	ZLG 319 AB	
-	-	NJ 319 EG15 C3		FI 21	V-95S	-	ZLG 319 AC	
-	3,5	6320 C3	6320 C3	FI 22	V-100S	ASG 6320	ZLG 320 AA	93
62	-	NU 320 EG15 C3		FI 27	V-120S	-	ZLG 320 AB	
-	-	NJ 320 EG15 C3		FI 22	V-100S	-	ZLG 320 AC	
-	3,5	6322 C3	6322 C3	FI 24	V-110S	ASG 6322	ZLG 322 AA	110
41	-	NU 322 EG15 C3		FI 29	V-130S	-	ZLG 322 AB	
-	-	NJ 322 EG15 C3		FI 24	V-110S	-	ZLG 322 AC	
-	3,0	6324 C3	6324 C3	FI 27	V-120S	ASG 6324	ZLG 324 AA	150
41	-	NU 324 EG15 C3		FI 32	V-140S	-	ZLG 324 AB	
-	-	NJ 324 EG15 C3		FI 27	V-120S	-	ZLG 324 AC	