

Mine Car Bearing Housings TVN 200

for bearings with cylindrical bore

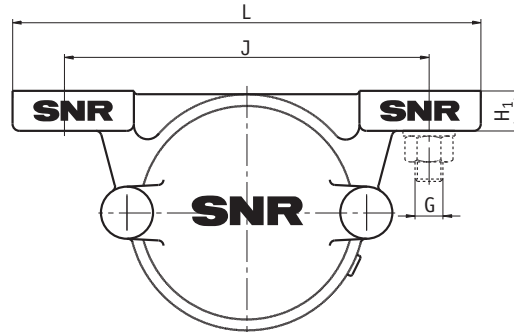
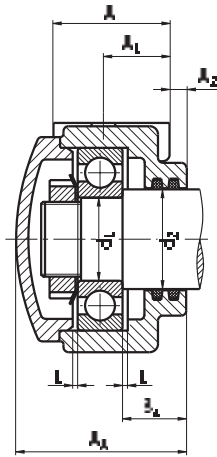

Design A
Housing for shaft ends

shaft		dimensions [mm]										
d ₁	d ₂	bearing housing code number	A _A	A _B	H	H ₁	J	L	A	A ₁	A ₂	B _a
20	25	TVN 204 A	61		35	14	110	150	45	25	6	23,5
	25	TVN 204 B		68	35	14	110	150	45	25	6	23,5
25	30	TVN 205 A	63		40	16	130	170	45	25	7	24,0
	30	TVN 205 B		71	40	16	130	170	45	25	7	24,0
30	35	TVN 206 A	71		50	16	150	190	52	30	7	27,0
	35	TVN 206 B		76	50	16	150	190	52	30	7	27,0
35	45	TVN 207 A	77		50	18	150	190	52	30	8	28,5
	45	TVN 207 B		78	50	18	150	190	52	30	8	28,5
40	50	TVN 208 A	86		60	18	170	210	60	35	8	33,0
	50	TVN 208 B		92	60	18	170	210	60	35	8	33,0
45	55	TVN 209 A	87		60	20	170	210	60	35	8	32,0
	55	TVN 209 B		92	60	20	170	210	60	35	8	32,0
50	60	TVN 210 A	90		60	20	170	210	60	35	8	34,0
	60	TVN 210 B		94	60	20	170	210	60	35	8	34,0
55	65	TVN 211 A	95		70	23	210	270	70	40	8	34,5
	65	TVN 211 B		100	70	23	210	270	70	40	8	34,5
60	70	TVN 212 A	102		70	23	210	270	70	40	10	39,0
	70	TVN 212 B		105	70	23	210	270	70	40	10	39,0
65	75	TVN 213 A	110		80	25	230	290	80	45	10	40,5
	75	TVN 213 B		115	80	25	230	290	80	45	10	40,5
70	80	TVN 214 A	111		80	25	230	290	80	45	10	40,5
	80	TVN 214 B		115	80	25	230	290	80	45	10	40,5
75	85	TVN 215 A	115		80	25	230	290	80	45	10	41,5
	85	TVN 215 B		117	80	25	230	290	80	45	10	41,5

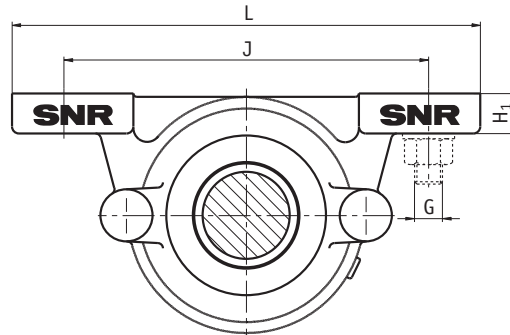
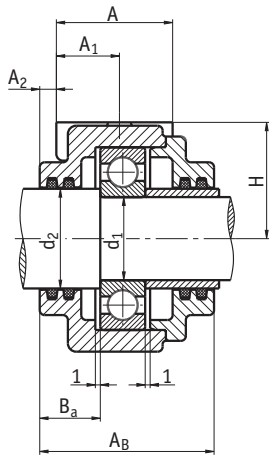

Design B
Housing for through shafts

fastening G	housing weight approx. kg	suitable bearings		felt strips*	lock nut	lock washer
		self-aligning ball bearing	deep groove ball bearing			
M12	1,2	1204	6204	FS 6 x 5 x 118	KM 4	MB 4
M12	1,2	1204	6204	FS 6 x 5 x 118		
M12	1,4	1205	6205	FS 6 x 5 x 132	KM 5	MB 5
M12	1,4	1205	6205	FS 6 x 5 x 132		
M12	2,2	1206	6206	FS 6 x 5 x 150	KM 6	MB 6
M12	2,2	1206	6206	FS 6 x 5 x 150		
M12	2,6	1207	6207	FS 6 x 5 x 180	KM 7	MB 7
M12	2,6	1207	6207	FS 6 x 5 x 180		
M12	3,7	1208	6208	FS 8 x 6,5 x 210	KM 8	MB 8
M12	3,7	1208	6208	FS 8 x 6,5 x 210		
M12	4,0	1209	6209	FS 8 x 6,5 x 225	KM 9	MB 9
M12	4,0	1209	6209	FS 8 x 6,5 x 225		
M12	4,2	1210	6210	FS 8 x 6,5 x 240	KM 10	MB 10
M12	4,2	1210	6210	FS 8 x 6,5 x 240		
M16	6,2	1211	6211	FS 8 x 6,5 x 260	KM 11	MB 11
M16	6,2	1211	6211	FS 8 x 6,5 x 260		
M16	6,7	1212	6212	FS 9 x 7,5 x 280	KM 12	MB 12
M16	6,7	1212	6212	FS 9 x 7,5 x 280		
M16	9,1	1213	6213	FS 9 x 7,5 x 300	KM 13	MB 13
M16	9,1	1213	6213	FS 9 x 7,5 x 300		
M16	9,4	1214	6214	FS 9 x 7,5 x 315	KM 14	MB 14
M16	9,4	1214	6214	FS 9 x 7,5 x 315		
M16	9,9	1215	6215	FS 9 x 7,5 x 330	KM 15	MB 15
M16	9,9	1215	6215	FS 9 x 7,5 x 330		

* = 2x for design A
4x for design B

TVN also available as hardening car
bearing housings for high temperature applications (s. p. 37).

Mine Car Bearing Housings TVN 300

for bearings with cylindrical bore

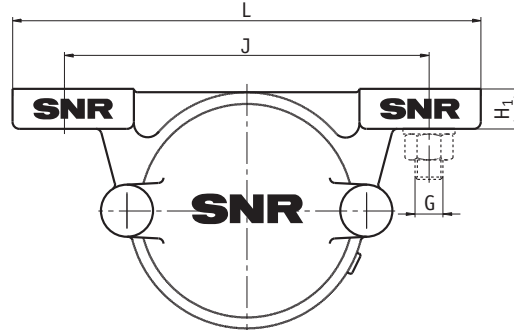
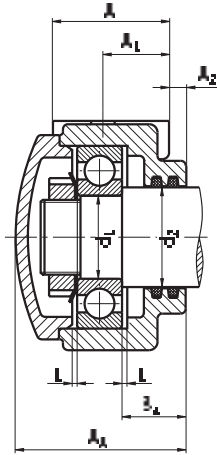

Design A
Housing for shaft ends

shaft		dimensions [mm]										
d ₁	d ₂	bearing housing code number	A _A	A _B	H	H ₁	J	L	A	A ₁	A ₂	B _a
20	25	TVN 304 A	63		40	16	130	170	45	25	7	24,0
	25	TVN 304 B		71	40	16	130	170	45	25	7	24,0
25	30	TVN 305 A	71		50	16	150	190	52	30	7	26,5
	30	TVN 305 B		76	50	16	150	190	52	30	7	26,5
30	40	TVN 306 A	77		50	18	150	190	52	30	8	27,5
	40	TVN 306 B		78	50	18	150	190	52	30	8	27,5
35	45	TVN 307 A	86		60	18	170	210	60	35	8	31,5
	45	TVN 307 B		92	60	18	170	210	60	35	8	31,5
40	50	TVN 308 A	90		60	20	170	210	60	35	8	32,5
	50	TVN 308 B		94	60	20	170	210	60	35	8	32,5
45	55	TVN 309 A	95		70	23	210	270	70	40	8	32,5
	55	TVN 309 B		100	70	23	210	270	70	40	8	32,5
50	60	TVN 310 A	102		70	23	210	270	70	40	10	36,5
	60	TVN 310 B		105	70	23	210	270	70	40	10	36,5
55	65	TVN 311 A	110		80	25	230	290	80	45	10	37,5
	65	TVN 311 B		115	80	25	230	290	80	45	10	37,5
60	70	TVN 312 A	115		80	25	230	290	80	45	10	38,5
	70	TVN 312 B		117	80	25	230	290	80	45	10	38,5
65	75	TVN 313 A	122		95	28	260	330	90	50	12	42,5
	75	TVN 313 B		127	95	28	260	330	90	50	12	42,5
70	80	TVN 314 A	126		95	28	260	330	90	50	12	43,5
	80	TVN 314 B		129	95	28	260	330	90	50	12	43,5
75	85	TVN 315 A	136		100	30	290	360	100	55	13	47,5
	85	TVN 315 B		139	100	30	290	360	100	55	13	47,5

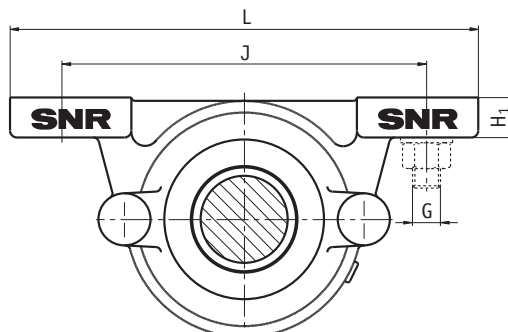
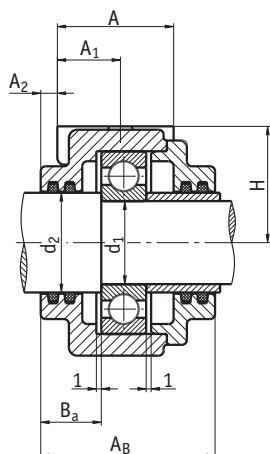

Design B
Housing for through shafts

fastening G	housing weight approx. kg	suitable bearings		felt strips*	lock nut	lock washer
		self-aligning ball bearing	deep groove ball bearing			
M12	1,6	1304	6304	FS 6 x 5 x 118	KM 4	MB 4
M12	1,6	1304	6304	FS 6 x 5 x 118		
M12	2,3	1305	6305	FS 6 x 5 x 132	KM 5	MB 5
M12	2,3	1305	6305	FS 6 x 5 x 132		
M12	2,6	1306	6306	FS 6 x 5 x 165	KM 6	MB 6
M12	2,6	1306	6306	FS 6 x 5 x 165		
M12	3,9	1307	6307	FS 6 x 5 x 180	KM 7	MB 7
M12	3,9	1307	6307	FS 6 x 5 x 180		
M12	4,2	1308	6308	FS 8 x 6,5 x 210	KM 8	MB 8
M12	4,2	1308	6308	FS 8 x 6,5 x 210		
M16	6,3	1309	6309	FS 8 x 6,5 x 225	KM 9	MB 9
M16	6,3	1309	6309	FS 8 x 6,5 x 225		
M16	6,9	1310	6310	FS 8 x 6,5 x 240	KM 10	MB 10
M16	6,9	1310	6310	FS 8 x 6,5 x 240		
M16	9,3	1311	6311	FS 8 x 6,5 x 260	KM 11	MB 11
M16	9,3	1311	6311	FS 8 x 6,5 x 260		
M16	10,0	1312	6312	FS 9 x 7,5 x 280	KM 12	MB 12
M16	10,0	1312	6312	FS 9 x 7,5 x 280		
M20	13,5	1313	6313	FS 9 x 7,5 x 300	KM 13	MB 13
M20	13,5	1313	6313	FS 9 x 7,5 x 300		
M20	14,0	1314	6314	FS 9 x 7,5 x 315	KM 14	MB 14
M20	14,0	1314	6314	FS 9 x 7,5 x 315		
M20	18,5	1315	6315	FS 9 x 7,5 x 330	KM 15	MB 15
M20	18,5	1315	6315	FS 9 x 7,5 x 330		

* = 2x for design A
4x for design B

TVN also available as hardening car
bearing housings for high temperature applications (s. p. 37).

Hardening Car Bearing Housings TVN 6200/6300 for bearing with cylindrical bore, for high temperature applications

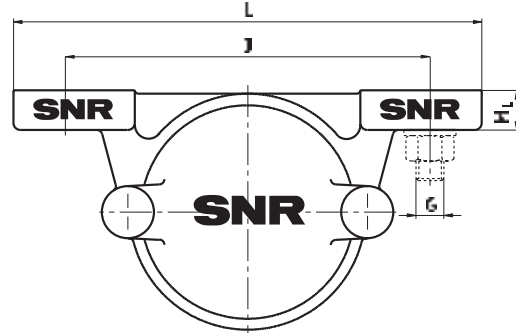
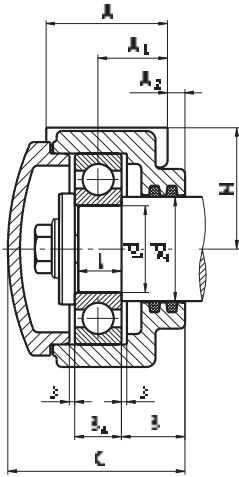

shaft		bearing housing		dimensions [mm]									
d ₁	d ₂	code number	C	H	H ₁	J	L	A	A ₁	A ₂	B	B _a	I
35	40	TVN 6207 A	76	50	18	210	255	57	38,5	10	17	30	15
40	45	TVN 6208 A	81	55	17	210	255	56	39	11	18	30	16
45	55	TVN 6309 A	96	70	18	210	256	55	44	10	25	32,5	23
50	60	TVN 6310 A	102	70	23	210	270	70	50	10	27	36,5	25
55	65	TVN 6211 A	95	70	23	210	270	70	45	8	21	34,5	19
65	75	TVN 6213 A	108,5	80	25	230	290	80	52	10	23	40,5	21

fastening G	weight approx. kg	suitable bearing deep groove ball bearing	Hostaflon TF 1645 filling quantity in g	hot steam packaging 2 x Arolan II
M16	2,6	6207 F605	50	6 x 6 x 145
M16	3,7	6208 F605	60	6 x 6 x 160
M16	6,3	6309 F605	95	6 x 6 x 175
M16	6,9	6310 F605	140	6 x 6 x 205
M16	6,2	6211 F605	110	6 x 6 x 220
M16	9,1	6213 F605	150	8 x 8 x 260

The listed bearing housings with deep groove ball bearing from series **62.. F605** and **63..F605** may only be used in the sand-lime brick hardening shop area.

For all other high temperature applications, e.g. clinker hardening plants, deep groove ball bearings from series **62..F600** and **63.. F600** must be used. The lubricant must also be changed: **Klüber Wolfrasyne U1af**.

Please contact an SNR engineer.