

Ball Transfer Units

R310EN 2910 (2006.11)

The Drive & Control Company

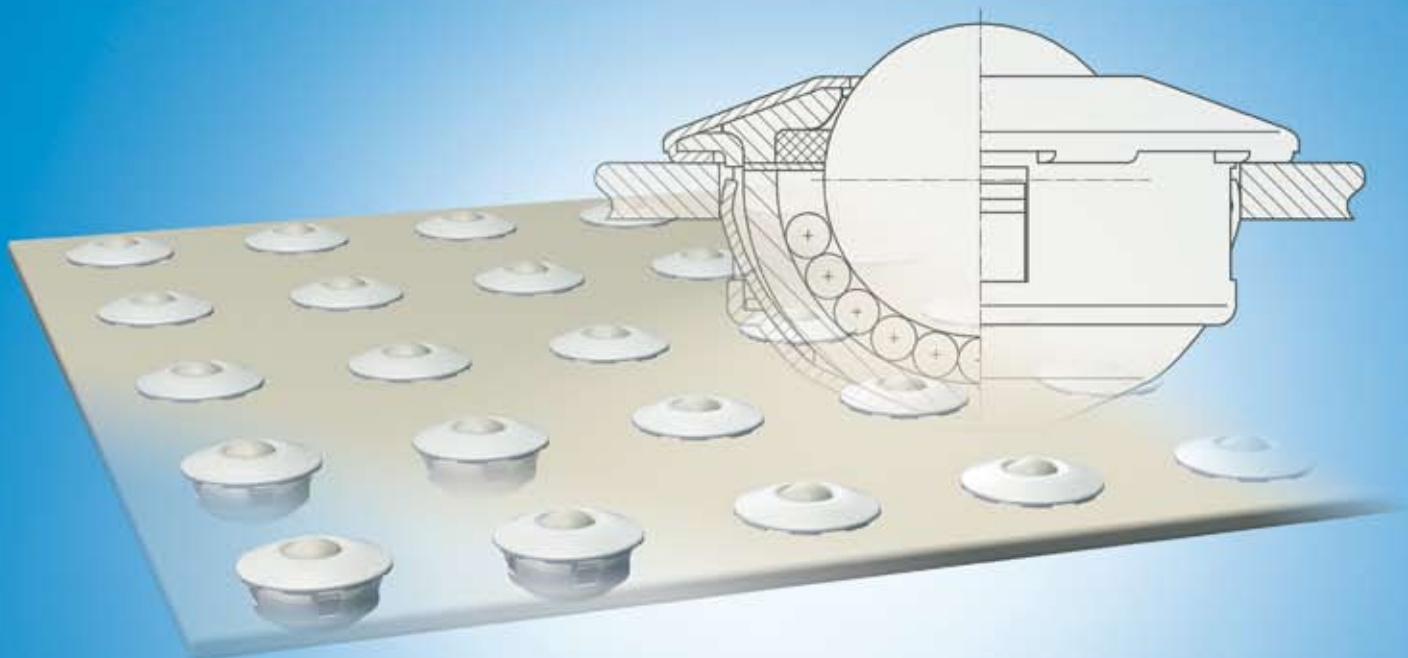

Linear Motion and Assembly Technologies

- Ball Rail Systems
- Roller Rail Systems
- Linear Bushings and Shafts
- Ball Screw Drives
- Linear Motion Systems
- Basic Mechanical Elements
- Manual Production Systems
- Transfer Systems

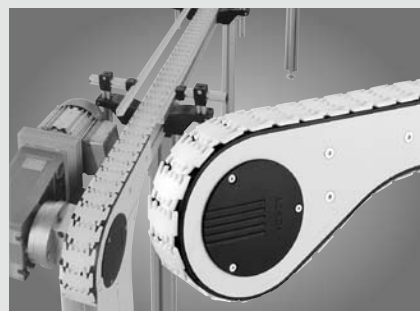
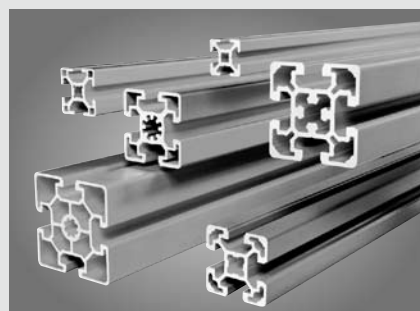
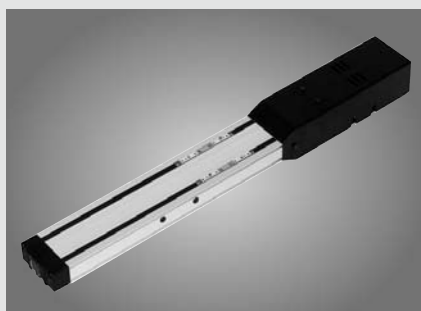

Ball Transfer Units

Product Overview	4
Technical Data	6
Dimensions, Load Capacities	10
with Sheet Steel Housing R0530	10
with Plastic Load Ball R0531	10
Spring-Loaded R0532	11
with Solid Steel Housing R0533	12
without Housing R0534	15
with Reinforced Sheet Steel Housing R0535	15
with Spring Clip R0536	16
with Plastic Housing R0530	17
Tolerance Ring / Mounting Tools	18
Tolerance Ring R0810	18
Mounting tool R0536 for Ball Transfer Units R0535 and R0536	18

Product Overview

Ball Transfer Units make light work of shifting, rotating and directing unit loads. They have proven extremely valuable as integral parts of conveyor systems, feed devices, and machining and packaging equipment.

Applications

- General-purpose machines
- Feed tables for sheet-metal working machines
- Fixtures for press brakes
- Feed devices for machining centers
- Drilling machine tables and motor-driven supporting tables
- Assembly aids in the manufacture of large engines and motors

Conveyor Systems

- Ball transfer tables, turntables and switches for sorting and distribution systems
- Crossover sections of continuous conveyors
- Baggage sorting systems at airports
- Transport of steel tubes and pipes
- Lifting platforms



Other Fields

- Construction of special-purpose machines
- Aerospace industry
- Beverage and stone-processing industries

Further highlights

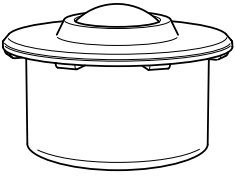
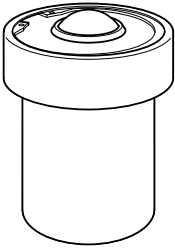

- Types for all standard applications and for many special solutions
- Easy mounting and extraction
- Conveying speed up to 2 m/sec in all types
- Consistently high quality
- High rationalization effect
- Smooth running
- Precise rolling and full load-bearing capability in any mounting orientation, even top-down

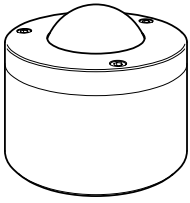
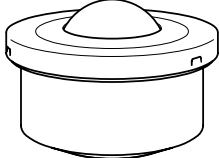
Ball Transfer Units

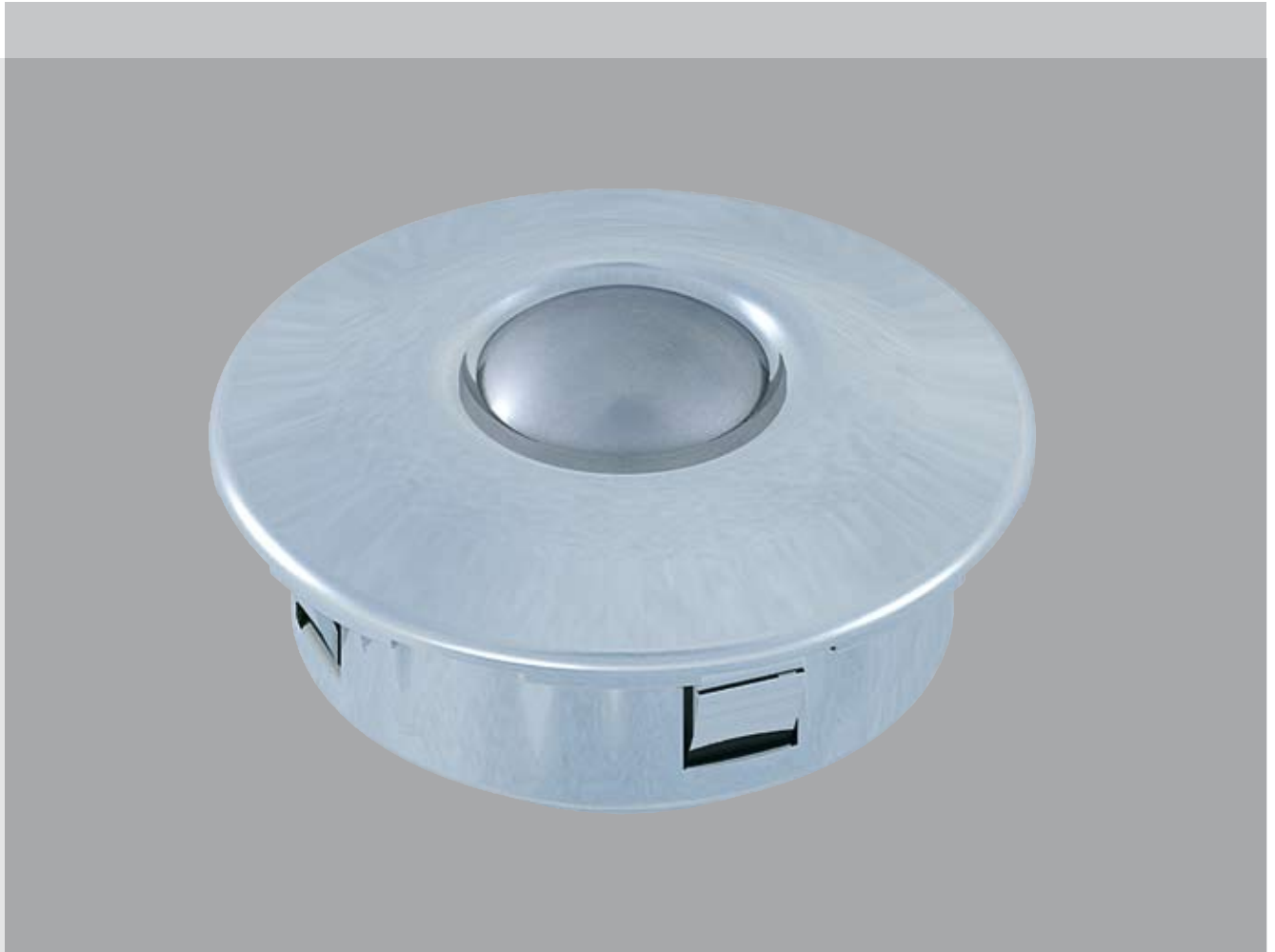
				
<p>with sheet steel housing 0530-...</p> <ul style="list-style-type: none"> - smallest ball transfer unit - for general applications <p>with plastic load ball 0531-...</p> <p>suitable particularly for transporting sensitive materials such as glass, polished aluminum, brass and steel sheets</p>	<p>spring-loaded 0532-...</p> <p>supported on springs and mounted under preload in a housing Ball Transfer Unit recedes into its housing under high loads</p>	<p>with steel housing 0533-...</p> <ul style="list-style-type: none"> - solid steel housing - without felt seal - very smooth movement 	<p>with steel housing 0533-...</p> <ul style="list-style-type: none"> - solid steel housing and cover - for very high loads 	<p>with steel housing 0533-...</p> <ul style="list-style-type: none"> - solid steel housing - for high loads

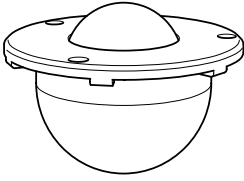
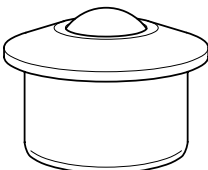
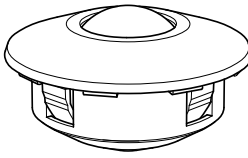

Ball Transfer Units

			
<p>without housing 0534-...</p> <ul style="list-style-type: none"> - low space requirement - simple mounting - mounting via holes in the collar 	<p>with sheet steel housing 0535-...</p> <ul style="list-style-type: none"> - reinforced housing and cover - for heavy impact loads 	<p>with spring clip 0536-...</p> <p>easily mountable and extractable from the load side. Fixing is by means of spring clips, which permit generous tolerances in the mounting hole.</p> <p>Reinforced cover to withstand heavy impact loads.</p>	<p>with plastic housing 0530-005-20</p> <p>for special applications</p>

Technical Data

Structural design of the Ball Transfer Units

A hardened ball cup serves as a raceway for a multitude of small supporting balls. The supporting balls roll against the ball cup when the load ball turns. Rexroth Ball Transfer Units are designed so that precise rolling and full load-bearing capability are ensured in any mounting orientation.

Ball Transfer Units require little maintenance, and almost every type is protected against dirt by an oil-soaked felt seal.

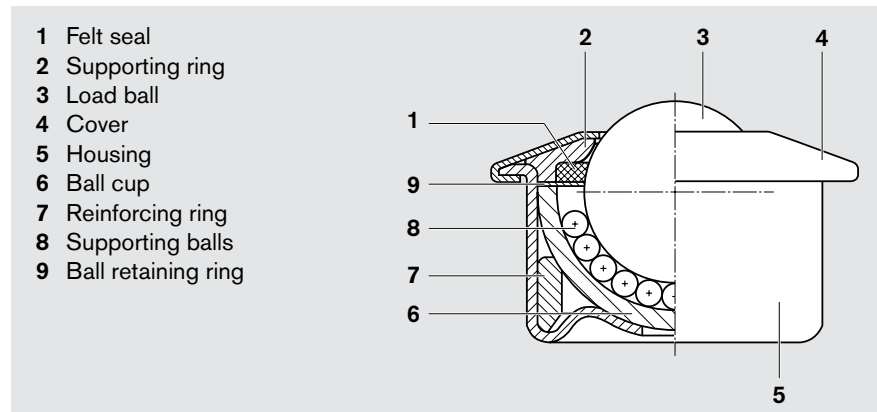

Ball Transfer Units in corrosion-preventive design

Corrosion, caused by moisture or chemical attack, can lead to impaired functioning or even failure of the Ball Transfer Units. Coated (galvanized + chromated) surfaces similar to EN 12329 specifications and/or higher-grade materials offer enhanced anticorrosion protection.

Galvanized covers and housings

offer simple protection against corrosion. In this type, the supporting balls and load balls are made from standard antifriction bearing steel and are protected from corrosive attack by the lubricant.

Galvanized internals, corrosion-resistant steel balls

Consistent coating of all internals and the use of corrosion-resistant steels for the antifriction bearing elements, similar to ISO 683-17 specifications, ensures comprehensive corrosion protection such as specified in ASTM B117-03.

All parts made from rust and acid resistant steel

(Antifriction bearing steel to EN 10088)

This type is selected if the conveyed articles are abrasive and/or there is exposure to an aggressive environment, especially to chemicals.

Since all versions have been designed to meet the high standards of ISO 281, even this type is unsuitable for underwater use.

Mounting possibilities

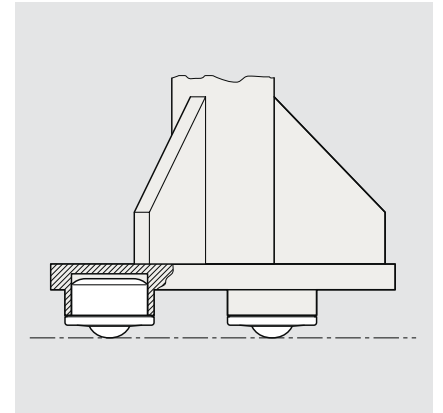
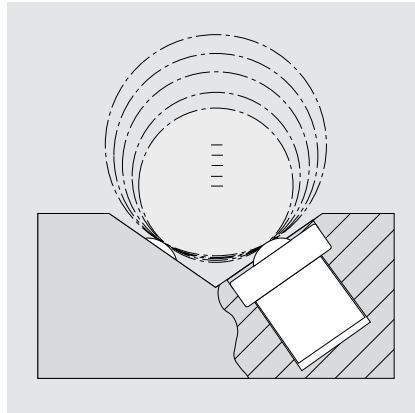
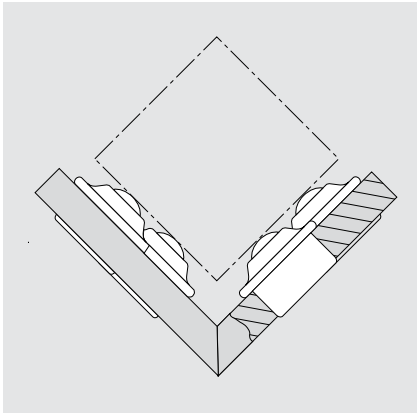

Application example

Ball Transfer Units used for assembling ball rail system runner blocks



Technical Data

Arrangement of the Ball Transfer Units

How the Ball Transfer Units should be arranged depends on the undersurface of the conveyed article. For articles with a uniform, smooth undersurface, such as boxes and cases, the distance between the Ball Transfer Units is calculated simply by dividing the smallest edge length by 2.5.

Example:
Undersurface of the conveyed article
= 500 x 1000 mm
Distance between Ball Transfer Units
 $a = \frac{500 \text{ mm}}{2.5} = 200 \text{ mm}$

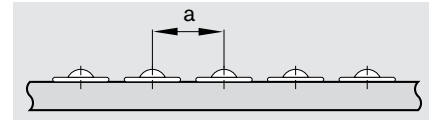

Determining the load for Ball Transfer Units

To determine the load for a Ball Transfer Unit, the weight of the conveyed article is divided by 3. If the load ball height tolerances are well-correlated, it is possible, depending on the nature of the conveyed article, to also perform the calculation based on the number of load-bearing Ball Transfer Units.

Example:
Mass = 3000 N
Ball Transfer Unit load
 $F = \frac{3000 \text{ N}}{3} = 1000 \text{ N}$

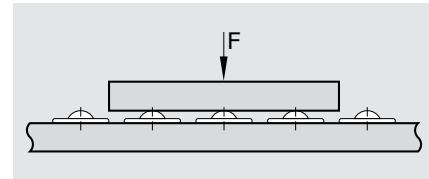

Spring-loaded Ball Transfer Units

The figures in the column headed "Preload" are most important when choosing the size for these types. The weight of the conveyed article is divided in this case by the number of load-bearing Ball Transfer Units.

Conveying speed

$$V_{\max} = 2 \text{ m/s}$$

Load capacity

The stated load capacities apply to all mounting orientations and relate to 10^6 rotations of the load ball. In case of prolonged periods of use at speeds above 1 m/sec, an increase in temperature and reduced nominal life must be expected as a function of the load, especially for sizes 60 to 120.

Calculation of the nominal life

$$L = \left(\frac{C}{F}\right)^3 \cdot 10^6$$

L = nominal life (rotations)
 C = Load capacity (N)
 F = load (N)

Friction coefficients

The diagram shows the friction coefficients of Ball Transfer Units as a function of load and speed. These guideline values apply to any mounting orientation for rolling contact on a hardened steel plate.

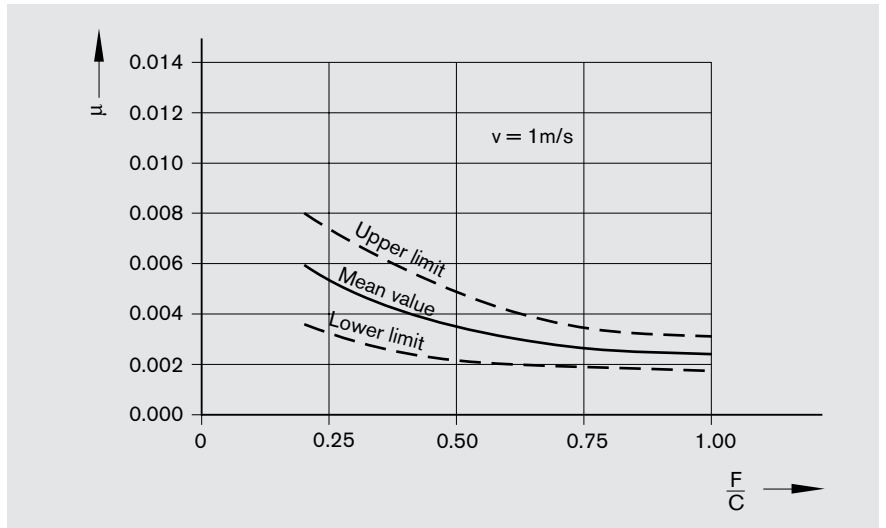

Operating temperature

Ball Transfer Unit with steel load ball:

up to 100 °C.
 At temperatures above 100 °C, only non-galvanized load balls without a felt seal should be used. Make allowance for reduction in load capacity. Use high-temperature lubricant! Follow the manufacturer's instructions! The existing lube oil may have to be washed out.

Ball Transfer Unit with plastic load ball:

up to 30 °C.
 At temperatures above 30 °C, make allowance for reduction in load capacity.

Temperature factor

for steel load ball:

for plastic load ball:

Temperature (°C)	Temperature factor f_T	Temperature (°C)	Temperature factor f_T
125	0.9	40	0.9
150	0.8	50	0.8
175	0.7	60	0.7
200	0.5	80	0.5

The load capacity must be multiplied by the temperature factor.

Lubrication

The lubrication must be adapted to the conveyed articles and to the ambient conditions. The lubricant (oil) can be introduced via the load ball.

Dimensions, Load Capacities

Ball Transfer Units with sheet steel housing R0530

– for general applications

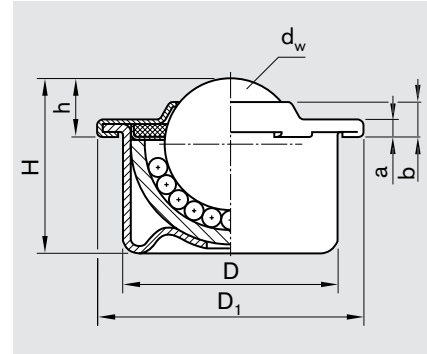
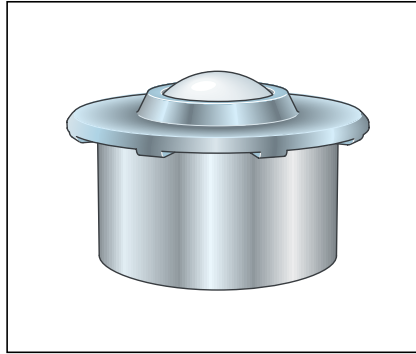

Part number	Execution	Dimensions (mm)							Load capacity (N)	Weight (kg)
		d _w	D	D ₁	h	H	a	b		
R0530 108 10 ¹⁾	Cover and housing galvanized	8	12.6 ± 0.055	17	4.8 ± 0.15	11.2	1.8	3.2	130	0.007
R0530 112 10 ¹⁾		12	18.0 ± 0.055	23	7.4 ± 0.15	15.5	2.0	4.3	250	0.018
R0530 115 10 ¹⁾²⁾		15	24.0 ± 0.065	31	9.5 ± 0.20	21.5	2.5	6.1	500	0.038
R0530 122 10 ²⁾		22	36.0 ± 0.080	45	9.8 ± 0.20	29.5	2.9	5.7	1300	0.132
R0530 130 10 ²⁾		30	45.0 ± 0.080	55	13.8 ± 0.30	37.5	3.7	7.9	2500	0.265
R0530 145 10 ²⁾		45	62.0 ± 0.095	75	19.0 ± 0.40	53.7	4.2	10.3	6000	0.720
R0530 208 10 ¹⁾	All parts galvanized, balls made from corrosion-resistant steel	8	12.6 ± 0.055	17	4.8 ± 0.15	11.2	1.8	3.2	100	0.007
R0530 212 10 ¹⁾		12	18.0 ± 0.055	23	7.4 ± 0.15	15.5	2.0	4.3	180	0.018
R0530 215 10 ¹⁾²⁾		15	24.0 ± 0.065	31	9.5 ± 0.20	21.5	2.5	6.1	370	0.038
R0530 222 10 ²⁾		22	36.0 ± 0.080	45	9.8 ± 0.20	29.5	2.9	5.7	970	0.132
R0530 230 10 ²⁾		30	45.0 ± 0.080	55	13.8 ± 0.30	37.5	3.7	7.9	1900	0.265
R0530 245 10 ²⁾		45	62.0 ± 0.095	75	19.0 ± 0.40	53.7	4.2	10.3	4500	0.720
R0530 608 00 ¹⁾	All parts made from corrosion-resistant steel	8	12.6 ± 0.055	17	4.8 ± 0.15	11.2	1.8	3.2	100	0.007
R0530 612 00 ¹⁾		12	18.0 ± 0.055	23	7.4 ± 0.15	15.5	2.0	4.3	180	0.018
R0530 615 00 ¹⁾²⁾		15	24.0 ± 0.065	31	9.5 ± 0.20	21.5	2.5	6.1	370	0.038
R0530 622 00 ²⁾		22	36.0 ± 0.080	45	9.8 ± 0.20	29.5	2.9	5.7	970	0.132
R0530 630 00 ²⁾		30	45.0 ± 0.080	55	13.8 ± 0.30	37.5	3.7	7.9	1900	0.265

Ball Transfer Units with plastic load ball R0531

– suitable for conveying sensitive articles

Part number	Execution	Dimensions (mm)							Load capacity ⁴⁾ (N)	Weight (kg)
		d _w	D	D ₁	h	H	a	b		
R0531 108 10 ¹⁾	Cover and housing galvanized	8	12.6 ± 0.055	17	4.8 ± 0.15	11.2	1.8	3.2	10	0.005
R0531 112 10 ¹⁾		12	18.0 ± 0.055	23	7.4 ± 0.15	15.5	2.0	4.3	35	0.012
R0531 115 10 ¹⁾²⁾		15	24.0 ± 0.065	31	9.5 ± 0.20	21.5	2.5	6.1	70	0.024
R0531 122 10 ²⁾³⁾		22	36.0 ± 0.080	45	9.6 ± 0.20	29.3	2.9	5.7	100	0.093
R0531 130 10 ²⁾³⁾		30	45.0 ± 0.080	55	13.6 ± 0.30	37.3	3.7	7.9	150	0.168
R0531 208 10 ¹⁾		All parts galvanized, load balls made from corrosion-resistant steel	8	12.6 ± 0.055	17	4.8 ± 0.15	11.2	1.8	3.2	10
R0531 212 10 ¹⁾	12		18.0 ± 0.055	23	7.4 ± 0.15	15.5	2.0	4.3	35	0.012
R0531 215 10 ¹⁾²⁾	15		24.0 ± 0.065	31	9.5 ± 0.20	21.5	2.5	6.1	70	0.024
R0531 222 10 ²⁾³⁾	22		36.0 ± 0.080	45	9.6 ± 0.20	29.3	2.9	5.7	100	0.093
R0531 230 10 ²⁾³⁾	30		45.0 ± 0.080	55	13.6 ± 0.30	37.3	3.7	7.9	150	0.168
R0531 608 00 ¹⁾	All parts made from corrosion-resistant steel		8	12.6 ± 0.055	17	4.8 ± 0.15	11.2	1.8	3.2	10
R0531 612 00 ¹⁾		12	18.0 ± 0.055	23	7.4 ± 0.15	15.5	2.0	4.3	35	0.012
R0531 615 00 ¹⁾²⁾		15	24.0 ± 0.065	31	9.5 ± 0.20	21.5	2.5	6.1	70	0.024
R0531 622 00 ²⁾³⁾		22	36.0 ± 0.080	45	9.6 ± 0.20	29.3	2.9	5.7	100	0.093
R0531 630 00 ²⁾³⁾		30	45.0 ± 0.080	55	13.6 ± 0.30	37.3	3.7	7.9	150	0.168

1) Without felt seal

2) Bottom hole for dirt discharge against surcharge

3) Dry felt seal

4) At 20 °C

Ball Transfer Units spring-loaded R0532

- supported on springs and mounted under preload in a housing
- Ball Transfer Unit recedes into its housing under high loads

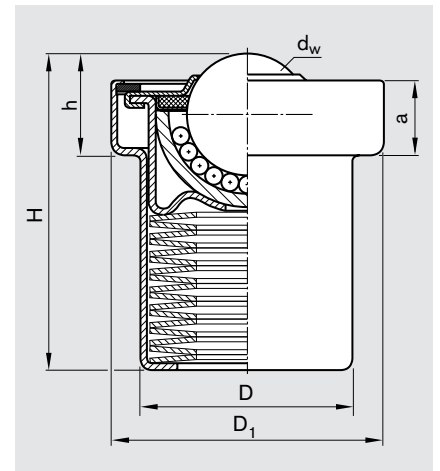
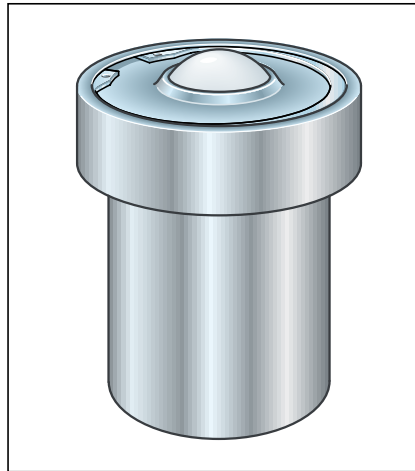

Part number	Execution	Dimensions (mm)						Preload (N)	Ultimate load ¹⁾ (N)	Tol. for preload and ultimate load (%)	Weight (kg)
		d _w	D	D ₁	h	H	a				
R0532 122 10	Cover and housing galvanized	22	38.8	50 ± 0.100	18.6	58.1	13.6	730	860	+25/-7.5	0.30
R0532 130 10		30	48.2	62 ± 0.125	24.4	70.0	17.0	1350	1600	+15/-7.5	0.60
R0532 145 10		45	66.4	85 ± 0.150	35.6	100.5	24.2	2280	2770	+15/-7.5	1.60
R0532 222 10	All parts galvanized, balls made from corrosion-resistant steel	22	38.8	50 ± 0.100	18.6	58.1	13.6	730	860	+25/-7.5	0.30
R0532 230 10		30	48.2	62 ± 0.125	24.4	70.0	17.0	1350	1600	+15/-7.5	0.60
R0532 245 10		45	66.4	85 ± 0.150	35.6	100.5	24.2	2280	2770	+15/-7.5	1.60
R0532 123 10 ²⁾	Galvanized	22	38.8	50 ± 0.100	18.6	58.1	13.6	170	250	+15/-7.5	0.28

1) Under ultimate load the Ball Transfer Unit recedes completely.

2) With helical spring

