

Triple Bearing Housings DLG 300

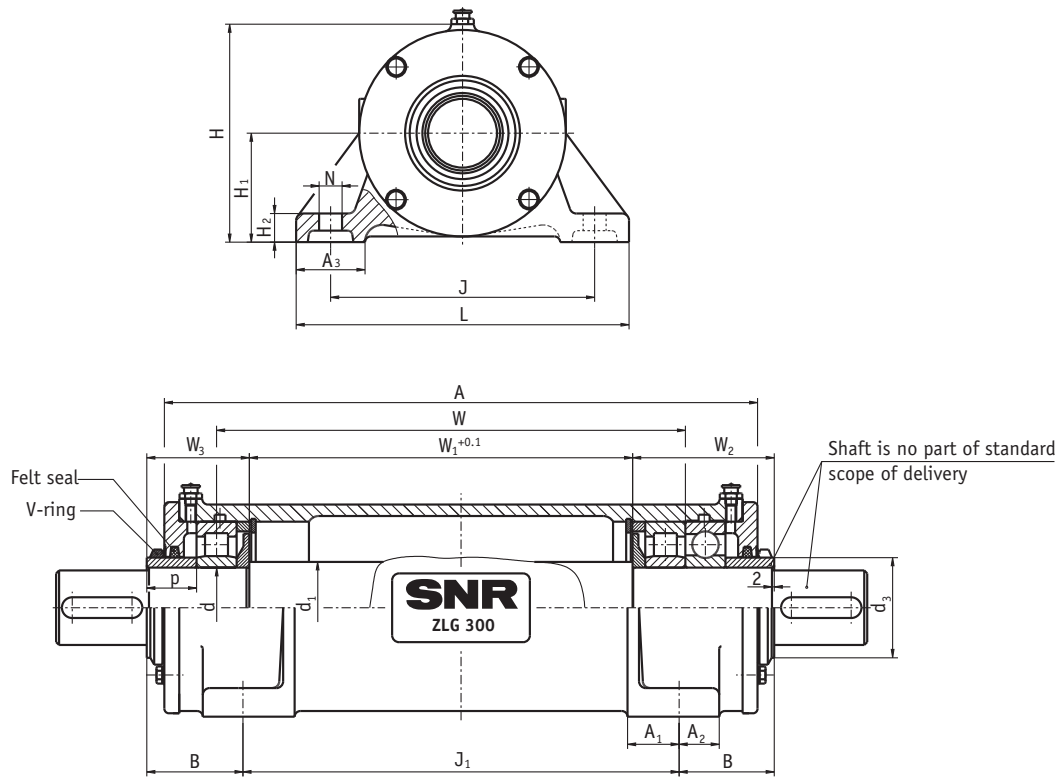

Design AD

		dimensions [mm]																				
shaft	bearing housing	d ₁	code number	A	A ₁	A ₂	A ₃	H	H ₁	H ₂	J	J ₁	L	N	W	W ₁	W ₂	W ₃	B	d ₃	p	as
70	80	DLG 314	517	45	35	60	190	95	25	230	380	290	20	408,5	334,0	124,0	89,0	83,5	80	43,0	-	-
														408,5	334,0	89,0	-	-				
														406,0	331,5	91,5	2,5	-				
75	90	DLG 315	553	45	35	70	200	100	28	260	400	330	20	438,5	359,0	130,5	93,5	91,5	90	44,5	-	-
														438,5	359,0	93,5	-	-				
														436,0	356,5	96,0	2,5	-				
80	95	DLG 316	577	50	40	70	220	112	30	260	420	330	20	460,0	377,5	134,5	95,5	94,0	95	44,5	-	-
														460,0	377,5	95,5	-	-				
														457,5	375,0	98,0	2,5	-				
85	100	DLG 317	593	50	40	70	225	112	30	290	440	350	20	469,0	385,5	139,5	98,5	92,0	100	46,5	-	-
														469,0	385,5	98,5	-	-				
														466,5	383,0	101,0	2,5	-				
90	105	DLG 318	599	55	45	70	230	112	30	290	460	350	20	474,0	387,5	144,5	101,5	87,0	110	47,5	-	-
														474,0	387,5	101,5	-	-				
														471,0	384,5	104,5	3,0	-				
95	110	DLG 319	626	60	50	90	248	125	35	320	480	400	24	498,0	407,5	149,0	104,0	90,5	110	47,5	-	-
														498,0	407,5	104,0	-	-				
														495,0	404,5	107,0	3,0	-				
100	115	DLG 320	657	60	50	80	264	130	40	320	500	400	24	525,5	432,0	153,0	106,0	95,5	120	47,5	-	-
														525,5	432,0	106,0	-	-				
														522,0	428,5	109,5	3,5	-				
110	130	DLG 322	678	70	60	100	296	150	40	380	520	450	26	555,5	457,5	152,5	102,5	96,5	130	41,0	-	-
														555,5	457,5	102,5	-	-				
														552,0	454,0	106,0	3,5	-				
120	140	DLG 324	705	78	60	115	320	160	40	410	540	500	35	575,0	469,5	162,5	107,5	100,0	140	41,0	-	-
														575,0	469,5	107,5	-	-				
														572,0	466,5	110,5	3,0	-				

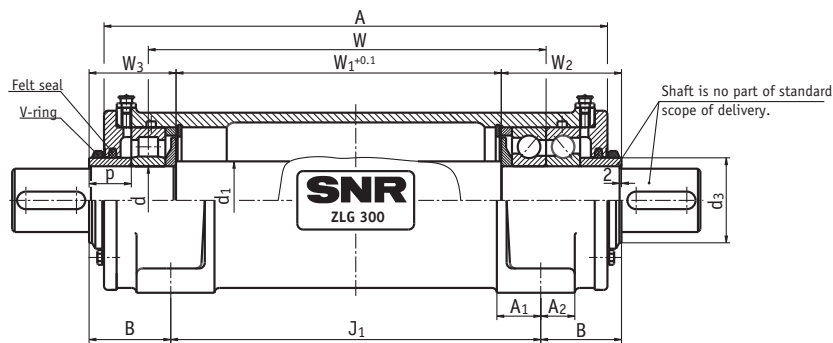

Design AE

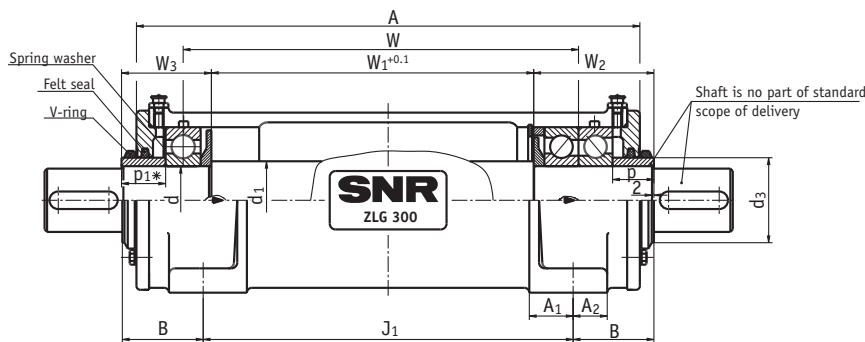

Design AF

* $p_1 = p + as$

If you notify us the dimensions of the mating structure for your design, we will be glad to supply you with double or triple bearing housings fully mounted, pre-lubricated and with a corresponding shaft. That means that you have the advantage of getting the complete unit from one supplier only.

mounting parts						unit	housing
bearing 1	bearing 2	felt ring	V-ring	spring washer	designation	approx. kg	
NU 314 EG15 C3	NU 314 EG15 C3 + 6314 C3	FI 18	V-80S	-	DLG 314 AD	37	
NU 314 EG15 C3	2 x 7314 BG			-	DLG 314 AE		
6314 C3	2 x 7314 BG			ASG 6314	DLG 314 AF		
NU 315 EG15 C3	NU 315 EG15 C3 + 6315 C3	FI 20	V-90S	-	DLG 315 AD	47	
NU 315 EG15 C3	2 x 7315 BG			-	DLG 315 AE		
6315 C3	2 x 7315 BG			ASG 6315	DLG 315 AF		
NU 316 EG15 C3	NU 316 EG15 C3 + 6316 C3	FI 21	V-95S	-	DLG 316 AD	56	
NU 316 EG15 C3	2 x 7316 BG			-	DLG 316 AE		
6316 C3	2 x 7316 BG			ASG 6316	DLG 316 AF		
NU 317 EG15 C3	NU 317 EG15 C3 + 6317 C3	FI 22	V-100S	-	DLG 317 AD	64	
NU 317 EG15 C3	2 x 7317 BG			-	DLG 317 AE		
6317 C3	2 x 7317 BG			ASG 6317	DLG 317 AF		
NU 318 EG15 C3	NU 318 EG15 C3 + 6318 C3	FI 24	V-110S	-	DLG 318 AD	71	
NU 318 EG15 C3	2 x 7318 BG			-	DLG 318 AE		
6318 C3	2 x 7318 BG			ASG 6318	DLG 318 AF		
NU 319 EG15 C3	NU 319 EG15 C3 + 6319 C3	FI 24	V-110S	-	DLG 319 AD	82	
NU 319 EG15 C3	2 x 7319 BG			-	DLG 319 AE		
6319 C3	2 x 7319 BG			ASG 6319	DLG 319 AF		
NU 320 EG15 C3	NU 320 EG15 C3 + 6320 C3	FI 27	V-120S	-	DLG 320 AD	93	
NU 320 EG15 C3	2 x 7320 BG			-	DLG 320 AE		
6320 C3	2 x 7320 BG			ASG 6320	DLG 320 AF		
NU 322 EG15 C3	NU 322 EG15 C3 + 6322 C3	FI 29	V-130S	-	DLG 322 AD	110	
NU 322 EG15 C3	2 x 7322 BG			-	DLG 322 AE		
6322 C3	2 x 7322 BG			ASG 6322	DLG 322 AF		
NU 324 EG15 C3	NU 324 EG15 C3 + 6324 C3	FI 32	V-140S	-	DLG 324 AD	150	
NU 324 EG15 C3	2 x 7324 BG			-	DLG 324 AE		
6324 C3	2 x 7324 BG			ASG 6324	DLG 324 AF		