

Drawn Cup Needle Roller Bearings

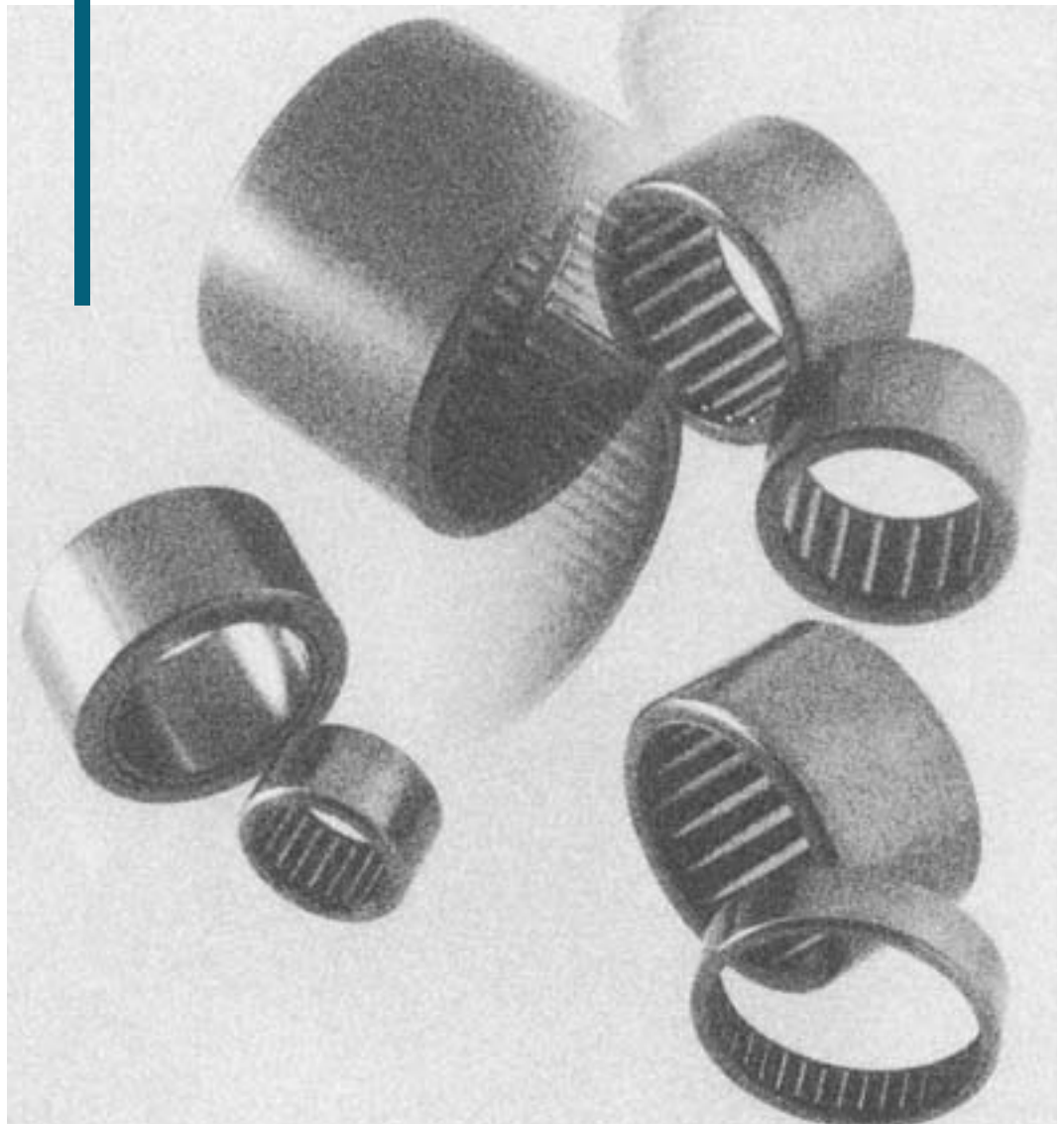

Drawn Cup Needle Roller Bearings

This bearing type is composed of an outer ring drawn from a thin steel plate by precision drawing, needle rollers and a cage assembled in the outer ring after the raceway surface thereof was hardened. Of the bearings with outer ring, this bearing type is a bearing with the smallest section height which enables space-saving and cost-saving.

Usually design is so made as to use a shaft as the direct raceway surface without using inner ring. The outer ring of this bearing type is of such a construction that the needle rollers and the cage are not separated from one another, so that the bearing is only press-fitted in a rigid housing with proper fit torque. Thus, this bearing type needs no snap ring, etc. to fix itself in axial direction and, in addition, is easy to handle.

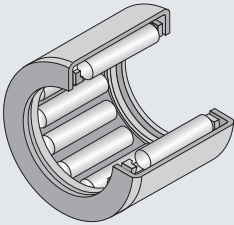
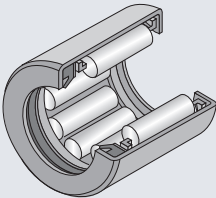
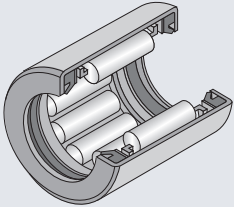
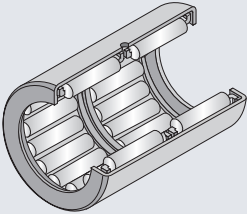
Type of bearing	Applied shaft diameter (mm)	Composition of nominal bearing number	Nominal bearing number	Code items and dimensions	Remarks
HK (HK·T2) 	Open end $\phi 3 \sim \phi 50$	HK 06 09 T2 Inscribed circle diameter Width Tail code Type code [Tail code] T2 : Resin cage C : Welding cage	HK0609T2	Inscribed circle diameter : $\phi 6$ Width : 9 T2 : Resin cage	The bearings with tail code T2 using polyamide resin cage shall be used at allowable temperature 120°C and, under continuous running, at 100°C and less.
HK·L 	Open end single side seal $\phi 12 \sim \phi 50$	HK 20 18 L Inscribed circle diameter Width Tail code Type code	HK2018L	Inscribed circle diameter : $\phi 20$ Width : 18 L : single side seal	This seal type (Tail code : L or LL) synthetic rubber seal built in at its single side or double sides is internally filled with lithium soap base grease. The operating temperature shall range from -25 to 100°C maximum to prevent deterioration of the seal and filled-up grease.
HK·LL 	Open end double-side seal $\phi 12 \sim \phi 50$	HK 20 20 LL Inscribed circle diameter Width Tail code Type code	HK2020LL	Inscribed circle diameter : $\phi 20$ Width : 20 LL: Double-side seal	The roller length and rated load of this bearing type are shorter and smaller than those of the open type of same dimension.
HK·ZWD 	Open end double-row type $\phi 15 \sim \phi 30$	HK 20 30 ZW D Inscribed circle diameter Width Tail code Tail code Type code	HK2030ZWD	Inscribed circle diameter : $\phi 20$ Width : 30 ZW : Double-row cage D : Outer ring with oil hole	This type is provided with oil hole on its outer ring.

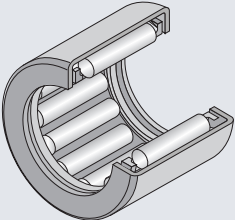
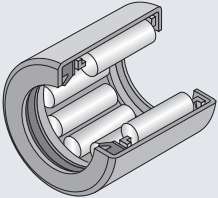
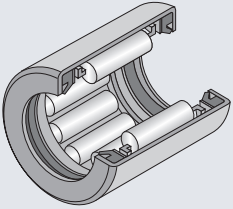
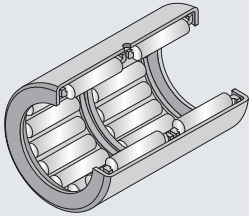
Type of bearing	Applied shaft diameter (mm)	Composition of nominal bearing number	Nominal bearing number	Code items and dimensions	Remarks	
 <p>HMK (HMK··T2)</p>	Open end	$\phi 8 \sim \phi 50$	<p>HMK 20 15</p> <p>Type code Inscribed circle diameter Width</p>	HMK2015	Inscribed circle diameter : $\phi 20$ Width : 15	The bearings with tail code T2 using polyamide resin cage shall be used at allowable temperature 120°C and, under continuous running, at 100°C and less.
 <p>HMK··L</p>	Open end single side seal	$\phi 8 \sim \phi 50$	<p>HMK 20 18 L</p> <p>Type code Inscribed circle diameter Width Tail code</p>	HMK2018L	Inscribed circle diameter : $\phi 20$ Width : 18 L : single side seal	This seal type (Tail code : L or LL) synthetic rubber seal built in at its single side or double sides is internally filled with lithium soap base grease. The operating temperature shall range from -25 to 100°C maximum to prevent deterioration of the seal and filled-up grease.
 <p>HMK··LL</p>	Open end double-side seal	$\phi 8 \sim \phi 50$	<p>HMK 20 21 LL</p> <p>Type code Inscribed circle diameter Width Tail code</p>	HMK2021LL	Inscribed circle diameter : $\phi 20$ Width : 21 LL: Double-side seal	The roller length and rated load of this bearing type are shorter and smaller than those of the open type of same dimension.
 <p>HMK··ZWD</p>	Open end double-row type	$\phi 38 \sim \phi 50$	<p>HMK 38 45 ZW D</p> <p>Type code Inscribed circle diameter Width Tail code Tail code</p>	HK3845ZWD	Inscribed circle diameter : $\phi 38$ Width : 45 ZW : Double-row cage D : Outer ring with oil hole	This type is provided with oil hole on its outer ring.

Heavy load series

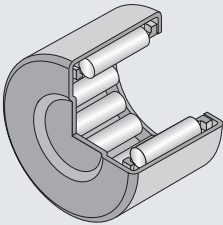
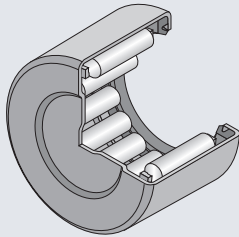
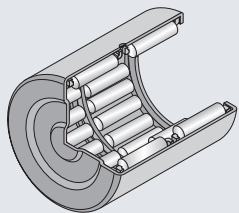
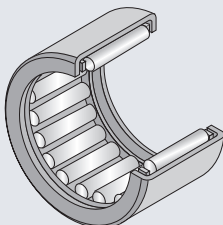
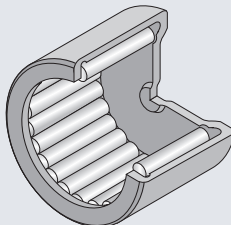
Type of bearing		Applied shaft diameter (mm)	Composition of nominal bearing number	Nominal bearing number	Code items and dimensions	Remarks	
BK (BK·T2) 	Standard series	Closed end	$\phi 3 \sim \phi 50$	BK 20 20 C Type code Inscribed circle diameter Width Tail code	BK2020C	Inscribed circle diameter : $\phi 20$ Width : 20 C : Welding cage	The bearings with tail code T2 using polyamide resin cage shall be used at allowable temperature 120°C and, under continuous running, at 100°C and less.
BK·L 		Closed end single side seal	$\phi 12 \sim \phi 50$	BK 20 18 L Type code Inscribed circle diameter Width Tail code	BK2018L	Inscribed circle diameter : $\phi 20$ Width : 18 L : single side seal	This seal type (Tail code: L) is internally filled up with lithium soap base grease. The operating temperature shall range from -25 to 100°C maximum to prevent deterioration of the seal and filled-up grease.
BK·ZWD 		Closed end double-row type	$\phi 15 \sim \phi 30$	BK 20 30 ZW D Type code Inscribed circle diameter Width Tail code Tail code	BK2030ZWD	Inscribed circle diameter : $\phi 20$ Width : 30 ZW : Double-row cage D : Outer ring with oil hole	Inscribed circle diameter
DCL 	Inch series	Open end	$\phi 6.35 \sim \phi 50.8$	DCL 16 20 Type code Inscribed circle diameter code Width code	DCL1620	Inscribed circle diameter : $\phi 25.4$ Width : 31.75	
HCK 	Bearing series for universal joints	Closed end	$\phi 10 \sim \phi 20$	HCK 16 22 Type code Inscribed circle diameter Outer diameter	HCK1622	Inscribed circle diameter : $\phi 16$ Width : $\phi 22$	Full complement roller type with no cage. Already filled up with specific grease.

Bearing Fits

It is common that drawn cup needle bearing is press-fitted in a housing by shrinkage fit so post press-fit inscribed circle diameter (F_w) comes to ISO Tolerance Rang Class F8. The post press-fit inscribed circle diameter (F_w) depends on the housing material and rigidity. It is therefore desirable to decide the interference based on the data measured in pre-testing.

Where the housing rigidity is adequately high, the post press-fit inscribed circle diameter (F_w) is secured in nearly F8 range and nearly ordinary radial clearance can be got by adopting the data of bearing fit in housing and on shaft as shown in **Table-1**.

Table 1 Bearing fit in housing and on shaft

Bearing type	Housing		Shaft	
	Iron series	Light alloy	Without inner ring	With inner ring
HK,BK	N6 (N7)	R6 (R7)	h5 (h6)	k5 (j6)
HMK,DCL	J6 (J7)	M6 (M7)		
HCK	F7	—	k6	—

Accuracy of housing bore

Because of its thin-walled outer ring, the performance of drawn cup needle roller bearing is greatly affected by the dimensional accuracy, profile accuracy and bore surface roughness of a housing in which the bearing is press-fitted. To avoid such an inverse affect, the housing bore(hole) must have the accuracy as specified in **Table 2**. For the shaft accuracy refer to **Subsection 7.3 "Accuracy of Shaft and Housing"** (on page A-39).

Table 2 Accuracy of housing bore

Property	Tolerance
Roundness (Max)	IT4 or less
Cylindricity (Max)	IT4 or less
Surface roughness (Max)	1.6a

Oil hole dimension in outer ring

The outer rings of double-row (Tail code : ZW) needle roller and cage assembly Type HK and Type BK are provided with an oil hole to facilitate oil lubrication to the bearing. **Table 3** shows the nominal oil hole diameter.

Table 3 Diameter of oil hole in outer ring (Metric system)

Outer ring diameter		Nominal oil hole diameter
Over	incl.	
5	10	1.5
10	20	2.0
20	40	2.5
40	80	3.0
80	200	3.5

Bearing installation

Any drawn cup needle roller bearings must be press-fitted in the housing in specific position by holding a specific jig in perfect contact with the mark-stamped side face of the bearing, without fail.

Further, hammering directly the bearing ring in installing (press-fitting) is not allowed absolutely. In installing, it is recommended to use a mandrel with O-ring as illustrated in **Fig.1** as a press-fitting jig. The use of this mandrel would enable to insert easily any drawn cup needle bearing in a housing without risk of twisting and fall-down.

Drawn cup needle roller bearing needs no a snap ring and a shoulder for positioning itself in a housing, **but the bearing must be press-fitted so carefully as not to allow its side face to strike the shoulder for preventing it from deforming, where press-fitted in a housing with shoulder.**

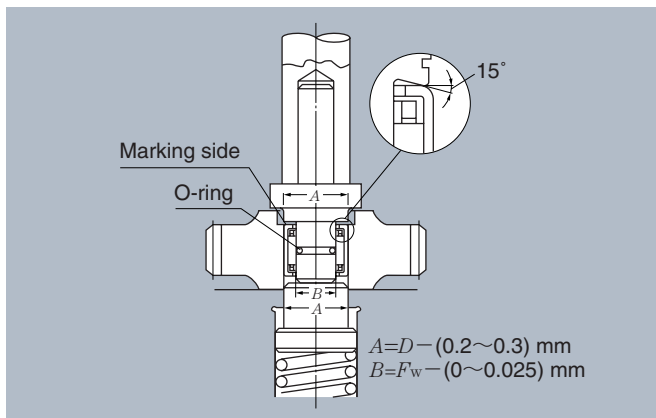

Fig. 1

The Type HCK for application to universal joints is fixed to the joint yoke by caulking, using a special-purposed assembler. Feel free to contact NTN for any inquiry about the special-purposed assembler (IPH Machine).

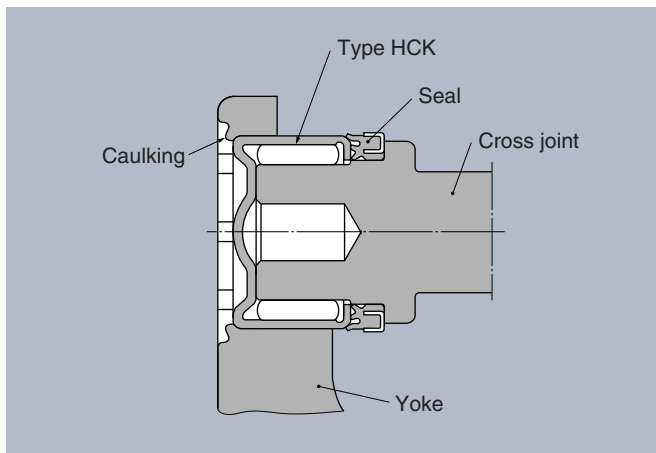

Fig. 2

Bearing Tolerances and Measuring Methods

The outer ring of drawn cup needle roller bearing is so thin-walled that deformation thereof to a certain extent is unavoidable in the manufacturing processes, particularly in the heat-treating process. However, the outer ring is so designed that it is reformed normally from such deformation when being press-fitted in a housing with specific dimensional accuracy and, as a result, it can have the accuracy required to fulfill its specific function.

Hence, **it is meaningless to measure the dimensional accuracy of bearing itself before being press-fitted. So, the following measuring method is used; a bearing to be measured is press-fitted in a linkage of specific dimension (20mm or more in wall**

thickness) and thereafter the inscribed circle diameter (F_w) is measured using a plug gauge or a taper gauge to evaluate the bearing accuracy.

Tables 4 to 7 show the dimensional tolerances for the bore diameter of each ring gauge and the inscribed circle diameter (F_w) each of standard metric series drawn cup needle roller bearings Type HK and BK, heavy load series Type HMK (metric series), inch series Type DCL, and inch series HCK for application to universal joints. When measuring the inscribed circle diameter of roller, the low tolerance for the inscribed circle diameter shall be applied to the dimension at "GO" side and the value of the high tolerance for the inscribed circle diameter plus (+) $2\mu\text{m}$ shall be applied to the dimension at "NOT GO" side in compliance with the relevant ISO standard.

Table 4 Dimensional tolerance for inscribed circle diameter (Type HK and BK)

Unit : mm

Nominal inscribed circle dia. F_w	Nominal outer ring outer dia. D	Ring gauge bore dia.	Tolerance for inscribed circle diameter	
			High	Low
3	6.5	6.484	3.016	3.006
4	8	7.984	4.022	4.010
5	9	8.984	5.022	5.010
6	10	9.984	6.022	6.010
7	11	10.980	7.028	7.013
8	12	11.980	8.028	8.013
9	13	12.980	9.028	9.013
10	14	13.980	10.028	10.013
12	16	15.980	12.034	12.016
12	18	17.980	12.034	12.016
13	19	18.976	13.034	13.016
14	20	19.976	14.034	14.016
15	21	20.976	15.034	15.016
16	22	21.976	16.034	16.016
17	23	22.976	17.034	17.016
18	24	23.976	18.034	18.016
20	26	25.976	20.041	20.020
22	28	27.976	22.041	22.020
25	32	31.972	25.041	25.020
28	35	34.972	28.041	28.020
30	37	36.972	30.041	30.020
35	42	41.972	35.050	35.025
40	47	46.972	40.050	40.025
45	52	51.967	45.050	45.025
50	58	57.967	50.050	50.025
55	63	62.967	55.060	55.030
60	68	67.967	60.060	60.030

Table 5 Dimensional tolerance for inscribed circle diameter (Type HMK)

Unit : mm

Nominal inscribed circle dia. F_w	Nominal outer ring outer dia. D	Ring gauge bore dia.	Tolerance for inscribed circle diameter	
			High	Low
8	15	14.995	8.028	8.013
9	16	15.995	9.028	9.013
10	17	16.995	10.028	10.013
12	19	18.995	12.034	12.016
14	22	21.995	14.034	14.016
15	22	21.995	15.034	15.016
16	24	23.995	16.034	16.016
17	24	23.995	17.034	17.016
18	25	24.995	18.034	18.016
19	27	26.995	19.041	19.020
20	27	26.995	20.041	20.020
21	29	28.995	21.041	21.020
22	29	28.995	22.041	22.020
24	31	30.994	24.041	24.020
25	33	32.994	25.041	25.020
26	34	33.994	26.041	26.020
28	37	36.994	28.041	28.020
29	38	37.994	29.041	29.020
30	40	39.994	30.041	30.020
32	42	41.994	32.050	32.025
35	45	44.994	35.050	35.025
37	47	46.994	37.050	37.025
38	48	47.994	38.050	38.025
40	50	49.994	40.050	40.025
45	55	54.994	45.050	45.025
50	62	61.994	50.050	50.025

Table 6 Dimensional tolerance for inscribed circle diameter (Type DCL)
Unit : mm

Nominal inscribed circle dia. F_w	Nominal outer ring outer dia. D	Ring gauge bore dia.	Tolerance for inscribed circle diameter	
			High	Low
6.350	11.112	11.125	6.411	6.388
7.938	12.700	12.713	7.998	7.976
9.525	14.288	14.300	9.586	9.563
11.112	15.875	15.888	11.173	11.151
12.700	17.462	17.475	12.761	12.738
14.288	19.050	19.063	14.348	14.326
15.875	20.638	20.650	15.936	15.913
17.462	22.225	22.238	17.523	17.501
19.050	25.400	25.387	19.086	19.063
20.638	26.988	26.975	20.673	20.650
22.225	28.575	28.562	22.261	22.238
23.812	30.162	30.150	23.848	23.825
25.400	31.750	31.737	25.436	25.413
26.988	33.338	33.325	27.023	27.000
28.575	34.925	34.912	28.611	28.588
30.162	38.100	38.087	30.198	30.175
31.750	38.100	38.087	31.786	31.763
34.925	41.275	41.262	34.963	34.938
38.100	47.625	47.612	38.141	38.113
41.275	50.800	50.787	41.316	41.288
44.450	53.975	53.962	44.493	44.463
47.625	57.150	57.137	47.668	47.638
50.800	60.325	60.312	50.846	50.815

Table 7 Dimensional tolerance for inscribed circle diameter (Type HCK)
Unit : mm

Nominal inscribed circle dia. F_w	Nominal outer ring outer dia. D	Ring gauge bore dia.	Tolerance for inscribed circle diameter	
			High	Low
10	15	15.016	10.026	10.011
11.656	17.1	17.116	11.687	11.669
13	19	19.020	13.031	13.013
14	20	20.020	14.031	14.013
16	22	22.020	16.031	16.013
18	24	24.020	18.031	18.013
18	24.6	24.620	18.031	18.013
20	27.9	27.920	20.038	20.017

Type HK, Type HK · · ZWD
 Type HMK
 Type BK, Type BK · · ZWD

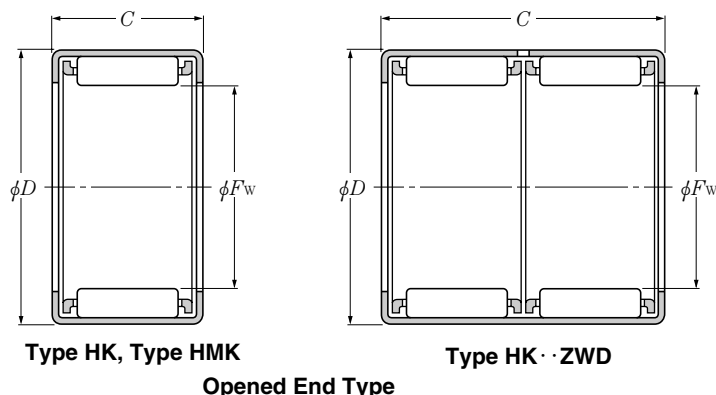

F_w 3~10mm

Boundary dimensions	Basic load ratings								Limiting speeds		Bearing numbers		Mass kg (approx.)	Appropriate ¹⁾ inner ring (as a reference)
	mm				N		kgf		r/min		open end design	closed end design		
	F_w	D	C 0 -0.2	C_1 max	C_r	C_{or}	C_r	C_{or}	grease	oil			(approx.)	
3	6.5	6	—	925	565	94	58	33 000	50 000	HK0306T2	—	0.0006	—	
	6.5	6	0.8	925	565	94	58	33 000	50 000	—	BK0306T2	0.0007	—	
4	8	8	—	1 770	1 270	180	129	30 000	45 000	HK0408T2	—	0.0016	—	
	8	8	1.6	1 770	1 270	180	129	30 000	45 000	—	BK0408T2	0.0018	—	
5	9	9	—	2 640	2 190	269	224	27 000	40 000	HK0509T2	—	0.0019	—	
	9	9	1.6	2 640	2 190	269	224	27 000	40 000	—	BK0509T2	0.0021	—	
6	10	9	—	2 660	2 280	272	233	25 000	37 000	HK0609T2	—	0.0022	—	
	10	9	1.6	2 660	2 280	272	233	25 000	37 000	—	BK0609T2	0.0024	—	
7	11	9	—	3 400	3 250	345	330	23 000	34 000	HK0709	—	0.0025	—	
	11	9	1.6	3 400	3 250	345	330	23 000	34 000	—	BK0709	0.0027	—	
8	12	10	—	3 850	3 950	395	400	20 000	30 000	HK0810C	—	0.0032	IR 5× 8×12	
	12	10	1.6	3 850	3 950	395	400	20 000	30 000	—	BK0810C	0.0034	IR 5× 8×12	
	15	10	—	3 800	2 870	390	293	20 000	30 000	HMK0810	—	0.0067	IR 5× 8×12	
	15	15	—	6 600	5 800	675	590	20 000	30 000	HMK0815	—	0.0100	IR 5× 8×16	
9	15	20	—	9 050	8 750	925	890	20 000	30 000	HMK0820T2	—	0.0130	—	
	13	10	—	4 750	5 300	485	540	18 000	27 000	HK0910	—	0.0035	IR 6× 9×12	
	13	10	1.6	4 750	5 300	485	540	18 000	27 000	—	BK0910	0.0039	IR 6× 9×12	
	13	12	—	5 650	6 650	575	680	18 000	27 000	HK0912	—	0.0042	IR 6× 9×12	
	13	12	1.6	5 650	6 650	575	680	18 000	27 000	—	BK0912	0.0045	IR 6× 9×12	
	16	12	—	5 300	4 450	540	455	18 000	27 000	HMK0912	—	0.0087	IR 6× 9×16	
10	16	16	—	7 400	6 850	755	700	18 000	27 000	HMK0916	—	0.0120	—	
	14	10	—	4 500	5 100	460	520	16 000	24 000	HK1010	—	0.0038	IR 7×10×10.5	
	14	10	1.6	4 500	5 100	460	520	16 000	24 000	—	BK1010	0.0042	IR 7×10×10.5	
	14	12	—	5 900	7 250	605	735	16 000	24 000	HK1012	—	0.0045	IR 7×10×16	
	14	12	1.6	5 900	7 250	605	735	16 000	24 000	—	BK1012	0.0050	IR 7×10×16	
	14	15	—	7 100	9 150	725	935	16 000	24 000	HK1015	—	0.0056	IR 7×10×16	
	14	15	1.6	7 100	9 150	725	935	16 000	24 000	—	BK1015	0.0062	IR 7×10×16	
	17	10	—	4 250	3 450	435	350	16 000	24 000	HMK1010	—	0.0079	IR 7×10×10.5	
17	12	—	5 600	4 850	570	495	16 000	24 000	HMK1012	—	0.0094	IR 7×10×16		

Note 1) Bearing with inner ring is represented by HK+IR. (Refer to "Inner Ring Dimensions Table" on page B-117.)
 EX. HK1012 + IR7×10×16.5

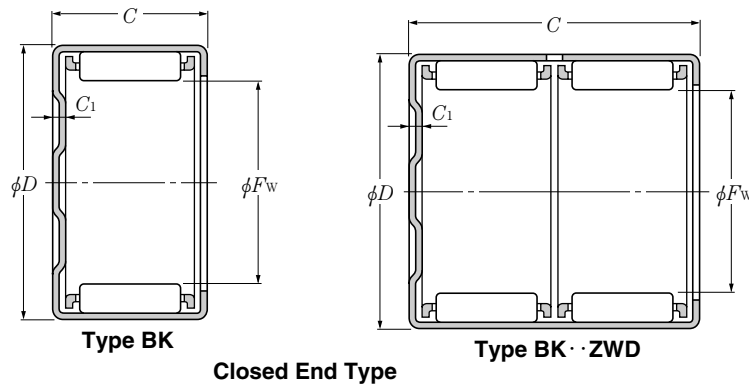

F_w 10~16mm

Boundary dimensions	Basic load ratings				Limiting speeds		Bearing numbers		Mass kg (approx.)	Appropriate ¹⁾ inner ring (as a reference)			
	mm				r/min		open end design	closed end design					
	F_w	D	C 0 -0.2	C_1 max	dynamic N	static kgf					grease	oil	
				C_r	C_{or}	C_r	C_{or}						
10	17	15	—	7 400	6 950	755	710	16 000	24 000	HMK1015	—	0.0120	IR 7×10×16
	17	20	—	10 200	10 500	1 040	1 070	16 000	24 000	HMK1020	—	0.0160	—
12	16	10	—	5 050	6 250	515	635	13 000	20 000	HK1210	—	0.0046	IR 8×12×10.5
	16	10	1.6	5 050	6 250	515	635	13 000	20 000	—	BK1210	0.0052	IR 8×12×10.5
	18	12	—	6 600	7 300	675	745	13 000	20 000	HK1212	—	0.0091	IR 8×12×12.5
	18	12	2.7	6 600	7 300	675	745	13 000	20 000	—	BK1212	0.0100	IR 8×12×12.5
	19	12	—	7 100	6 900	725	705	13 000	20 000	HMK1212	—	0.0110	IR 8×12×12.5
	19	15	—	9 400	9 900	955	1 010	13 000	20 000	HMK1215	—	0.0140	IR 9×12×16
	19	20	—	12 300	14 000	1 260	1 430	13 000	20 000	HMK1220	—	0.0180	—
13	19	25	—	15 300	18 600	1 560	1 890	13 000	20 000	HMK1225	—	0.0230	—
	19	12	—	6 950	7 900	705	805	12 000	18 000	HK1312	—	0.0100	IR10×13×12.5
14	19	12	2.7	6 950	7 900	705	805	12 000	18 000	—	BK1312	0.0110	IR10×13×12.5
	20	12	—	7 200	8 500	735	865	11 000	17 000	HK1412	—	0.0110	IR10×14×13
	20	12	2.7	7 200	8 500	735	865	11 000	17 000	—	BK1412	0.0120	IR10×14×13
	20	16	—	10 700	14 000	1 090	1 430	11 000	17 000	HK1416	—	0.0150	—
	20	16	2.7	10 700	14 000	1 090	1 430	11 000	17 000	—	BK1416	0.0160	—
	22	16	—	11 500	12 000	1 180	1 220	11 000	17 000	HMK1416	—	0.0190	IR10×14×20
15	22	20	—	14 600	16 200	1 490	1 650	11 000	17 000	HMK1420	—	0.0240	—
	21	12	—	7 500	9 100	765	930	11 000	16 000	HK1512	—	0.0110	IR12×15×12.5
	21	12	2.7	7 500	9 100	765	930	11 000	16 000	—	BK1512	0.0130	IR12×15×12.5
	21	16	—	10 700	14 400	1 090	1 470	11 000	16 000	HK1516	—	0.0150	IR12×15×16.5
	21	16	2.7	10 700	14 400	1 090	1 470	11 000	16 000	—	BK1516	0.0170	IR12×15×16.5
	21	22	—	12 900	18 200	1 310	1 860	11 000	16 000	HK1522ZWD	—	0.0200	IR12×15×22.5
	21	22	2.7	12 900	18 200	1 310	1 860	11 000	16 000	—	BK1522ZWD	0.0220	IR12×15×22.5
	22	10	—	6 100	6 000	620	610	11 000	16 000	HMK1510	—	0.0110	IR10×15×12.5
	22	12	—	7 950	8 450	810	860	11 000	16 000	HMK1512	—	0.0130	IR12×15×12.5
	22	15	—	10 900	12 700	1 120	1 300	11 000	16 000	HMK1515	—	0.0160	IR12×15×16
	22	20	—	14 900	18 900	1 510	1 920	11 000	16 000	HMK1520	—	0.0220	IR12×15×22.5
22	25	—	18 500	25 000	1 880	2 550	11 000	16 000	HMK1525	—	0.0270	—	
16	22	12	—	7 750	9 700	795	990	10 000	15 000	HK1612	—	0.0120	IR12×16×13

Note 1) Bearing with inner ring is represented by HK+IR. (Refer to "Inner Ring Dimensions Table" on page B-117, B118.)
EX. HK1312 + IR10×13×12.5

Type HK, Type HK · · ZWD
 Type HMK
 Type BK, Type BK · · ZWD

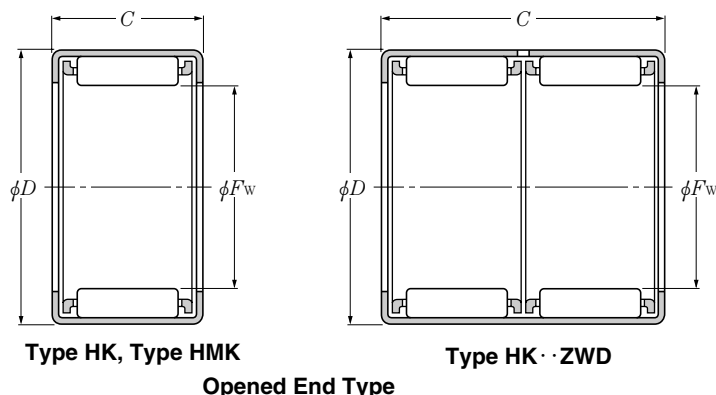

F_w 16~20mm

Boundary dimensions				Basic load ratings				Limiting speeds		Bearing numbers		Mass	Appropriate ¹⁾ inner ring
F_w	mm			dynamic	static	dynamic	static	grease	oil	open end design	closed end design	kg (approx.)	(as a reference)
	D	C 0 -0.2	C_1 max	N	N	kgf	kgf						
				C_r	C_{or}	C_r	C_{or}						
16	22	12	2.7	7 750	9 700	795	990	10 000	15 000	—	BK1612	0.014	IR12×16×13
	22	16	—	11 100	15 300	1 130	1 560	10 000	15 000	HK1616	—	0.016	IR12×16×20
	22	16	2.7	11 100	15 300	1 130	1 560	10 000	15 000	—	BK1616	0.018	IR12×16×20
	22	22	—	13 300	19 400	1 360	1 980	10 000	15 000	HK1622ZWD	—	0.022	—
	22	22	2.7	13 300	19 400	1 360	1 980	10 000	15 000	—	BK1622ZWD	0.023	—
	24	16	—	12 400	13 500	1 260	1 370	10 000	15 000	HMK1616	—	0.021	IR12×16×20
	24	20	—	15 600	18 200	1 590	1 860	10 000	15 000	HMK1620	—	0.027	IR12×16×22
17	23	12	—	8 500	11 100	865	1 130	9 500	14 000	HK1712	—	0.012	—
	23	12	2.7	8 500	11 100	865	1 130	9 500	14 000	—	BK1712	0.015	—
	24	15	—	12 100	15 000	1 230	1 530	9 500	14 000	HMK1715	—	0.018	IR14×17×17
	24	20	—	15 200	20 000	1 540	2 040	9 500	14 000	HMK1720C	—	0.024	IR12×17×20.5
	24	25	—	19 300	27 400	1 970	2 790	9 500	14 000	HMK1725B	—	0.030	IR12×17×25.5
18	24	12	—	8 300	10 900	845	1 110	8 500	13 000	HK1812	—	0.013	IR15×18×12.5
	24	12	2.7	8 300	10 900	845	1 110	8 500	13 000	—	BK1812	0.015	IR15×18×12.5
	24	16	—	11 800	17 300	1 210	1 760	8 500	13 000	HK1816	—	0.018	IR15×18×16.5
	24	16	2.7	11 800	17 300	1 210	1 760	8 500	13 000	—	BK1816	0.020	IR15×18×16.5
	25	13	—	10 200	12 200	1 040	1 240	8 500	13 000	HMK1813	—	0.016	IR15×18×16
	25	15	—	12 000	15 100	1 220	1 540	8 500	13 000	HMK1815	—	0.019	IR15×18×16
	25	17	—	13 800	18 000	1 400	1 830	8 500	13 000	HMK1817	—	0.021	IR15×18×17.5
	25	19	—	15 500	20 900	1 580	2 130	8 500	13 000	HMK1819	—	0.024	IR15×18×20.5
	25	20	—	16 300	22 300	1 660	2 280	8 500	13 000	HMK1820	—	0.025	IR15×18×20.5
	25	25	—	20 300	29 600	2 070	3 000	8 500	13 000	HMK1825	—	0.031	IR15×18×25.5
19	27	16	—	13 900	16 300	1 410	1 660	8 500	13 000	HMK1916	—	0.025	IR15×19×20
	27	20	—	17 500	22 100	1 790	2 250	8 500	13 000	HMK1920	—	0.031	—
20	26	12	—	9 250	13 000	945	1 330	8 000	12 000	HK2012C	—	0.014	IR15×20×13
	26	12	2.7	9 250	13 000	945	1 330	8 000	12 000	—	BK2012	0.017	IR15×20×13
	26	16	—	13 000	20 100	1 320	2 050	8 000	12 000	HK2016	—	0.019	IR17×20×16.5
	26	16	2.7	13 000	20 100	1 320	2 050	8 000	12 000	—	BK2016	0.022	IR17×20×16.5
	26	20	—	16 400	27 100	1 670	2 760	8 000	12 000	HK2020C	—	0.024	IR17×20×20.5
	26	20	2.7	16 400	27 100	1 670	2 760	8 000	12 000	—	BK2020C	0.027	IR17×20×20.5

Note 1) Bearing with inner ring is represented by HK+IR. (Refer to "Inner Ring Dimensions Table" on page B-118, B119.)
 EX. HK1812 + IR15×18×12.5

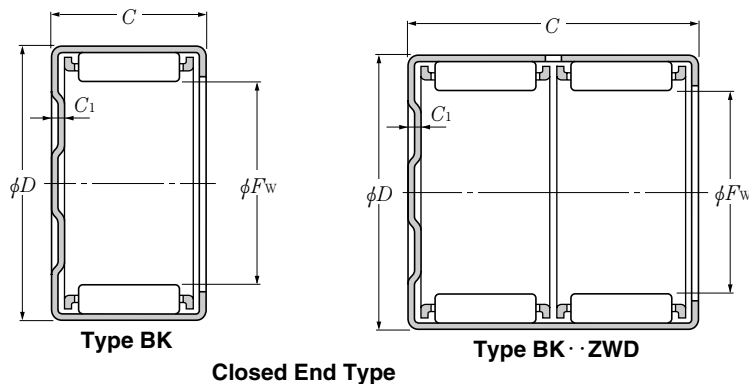

F_w 20~25mm

Boundary dimensions				Basic load ratings				Limiting speeds		Bearing numbers		Mass	Appropriate ¹⁾ inner ring
F_w	mm			N		kgf		grease	oil	open end design	closed end design	kg (approx.)	(as a reference)
	D	C 0 -0.2	C_1 max	C_r	C_{or}	C_r	C_{or}						
20	26	30	—	22 200	40 000	2 270	4 100	8 000	12 000	HK2030ZWD	—	0.035	IR17×20×30.5
	26	30	2.7	22 200	40 000	2 270	4 100	8 000	12 000	—	BK2030ZWD	0.037	IR17×20×30.5
	27	15	—	13 000	17 300	1 330	1 760	8 000	12 000	HMK2015	—	0.021	IR17×20×16.5
	27	20	—	17 700	25 600	1 800	2 610	8 000	12 000	HMK2020	—	0.027	IR17×20×20.5
	27	25	—	22 000	34 000	2 240	3 450	8 000	12 000	HMK2025	—	0.034	IR15×20×26
	27	30	—	26 100	42 000	2 660	4 300	8 000	12 000	HMK2030	—	0.041	IR17×20×30.5
21	29	16	—	15 300	19 100	1 560	1 940	7 500	11 000	HMK2116	—	0.027	IR17×21×20
	29	20	—	19 400	25 800	1 970	2 630	7 500	11 000	HMK2120	—	0.033	—
22	28	12	—	9 750	14 300	995	1 460	7 500	11 000	HK2212	—	0.013	IR17×22×13
	28	12	2.7	9 750	14 300	995	1 460	7 500	11 000	—	BK2212	0.015	IR17×22×13
	28	16	—	13 600	22 100	1 390	2 250	7 500	11 000	HK2216C	—	0.021	IR17×22×18
	28	16	2.7	13 600	22 100	1 390	2 250	7 500	11 000	—	BK2216	0.024	IR17×22×18
	28	20	—	17 200	29 800	1 760	3 050	7 500	11 000	HK2220C	—	0.026	IR17×22×20.5
	28	20	2.7	17 200	29 800	1 760	3 050	7 500	11 000	—	BK2220	0.030	IR17×22×20.5
	29	10	—	8 400	10 100	855	1 030	7 500	11 000	HMK2210	—	0.015	IR17×22×13
	29	15	—	13 400	18 500	1 370	1 890	7 500	11 000	HMK2215	—	0.022	IR17×22×16D
	29	20	—	18 200	27 400	1 860	2 790	7 500	11 000	HMK2220	—	0.030	IR17×22×20.5
	29	25	—	23 600	38 500	2 410	3 900	7 500	11 000	HMK2225	—	0.037	IR17×22×26
24	31	20	—	18 800	29 100	1 910	2 970	6 500	10 000	HMK2420	—	0.032	—
	31	28	—	26 000	44 500	2 650	4 500	6 500	10 000	HMK2428	—	0.045	IR20×24×28.5
25	32	12	—	11 800	16 300	1 200	1 660	6 500	9 500	HK2512	—	0.021	IR20×25×12.5
	32	12	2.7	11 800	16 300	1 200	1 660	6 500	9 500	—	BK2512	0.023	IR20×25×12.5
	32	16	—	15 900	24 000	1 620	2 450	6 500	9 500	HK2516	—	0.027	IR20×25×17
	32	16	2.7	15 900	24 000	1 620	2 450	6 500	9 500	—	BK2516	0.031	IR20×25×17
	32	20	—	20 300	33 000	2 070	3 350	6 500	9 500	HK2520	—	0.034	IR20×25×20.5
	32	20	2.7	20 300	33 000	2 070	3 350	6 500	9 500	—	BK2520	0.039	IR20×25×20.5
	32	26	—	26 400	46 000	2 690	4 700	6 500	9 500	HK2526	—	0.045	IR20×25×26.5
	32	26	2.7	26 400	46 000	2 690	4 700	6 500	9 500	—	BK2526	0.049	IR20×25×26.5
32	38	—	35 000	65 500	3 550	6 700	6 500	9 500	HK2538ZWD	—	0.065	IR20×25×38.5	

Note 1) Bearing with inner ring is represented by HK+IR. (Refer to "Inner Ring Dimensions Table" on page B-119, B120.)
EX. HK2512 + IR20×25×12.5

Type HK, Type HK · · ZWD
 Type HMK, Type HMK · · ZWD
 Type BK, Type BK · · ZWD

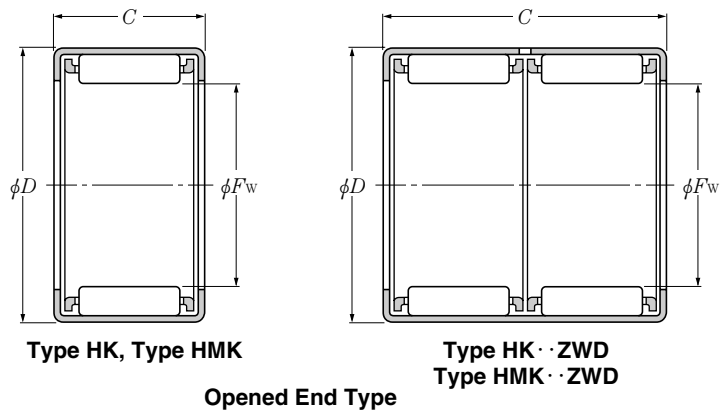

F_w 25~30mm

Boundary dimensions				Basic load ratings				Limiting speeds		Bearing numbers		Mass	Appropriate ¹⁾ inner ring
F_w	mm			dynamic	static	dynamic	static	r/min		open end	closed end	kg (approx.)	(as a reference)
	D	C 0 -0.2	C_1 max	N	N	kgf	kgf	grease	oil	design	design		
25	32	38	2.7	35 000	65 500	3 550	6 700	6 500	9 500	—	BK2538ZWD	0.069	IR20×25×38.5
	33	10	—	9 150	10 400	935	1 060	6 500	9 500	HMK2510	—	0.019	IR20×25×12.5
	33	15	—	15 200	19 900	1 550	2 030	6 500	9 500	HMK2515C	—	0.029	IR20×25×16
	33	20	—	21 800	31 500	2 220	3 200	6 500	9 500	HMK2520	—	0.039	IR20×25×20.5
	33	25	—	26 700	41 000	2 720	4 200	6 500	9 500	HMK2525	—	0.048	IR20×25×26.5
	33	30	—	32 500	53 000	3 300	5 400	6 500	9 500	HMK2530	—	0.058	IR20×25×32
26	34	16	—	17 200	23 300	1 750	2 380	6 000	9 000	HMK2616	—	0.032	IR22×26×20
	34	20	—	21 800	31 500	2 220	3 200	6 000	9 000	HMK2620	—	0.040	—
28	35	16	—	17 300	27 600	1 760	2 820	5 500	8 500	HK2816	—	0.030	IR22×28×17
	35	16	2.7	17 300	27 600	1 760	2 820	5 500	8 500	—	BK2816	0.034	IR22×28×17
	35	20	—	21 300	36 000	2 170	3 700	5 500	8 500	HK2820	—	0.038	IR22×28×20.5
	35	20	2.7	21 300	36 000	2 170	3 700	5 500	8 500	—	BK2820	0.043	IR22×28×20.5
	37	20	—	23 600	32 500	2 410	3 350	5 500	8 500	HMK2820	—	0.049	IR22×28×20.5
	37	30	—	35 000	54 500	3 600	5 550	5 500	8 500	HMK2830	—	0.073	—
29	38	20	—	24 600	35 000	2 510	3 550	5 500	8 500	HMK2920	—	0.050	—
	38	30	—	34 500	54 000	3 550	5 550	5 500	8 500	HMK2930	—	0.075	—
30	37	12	—	13 000	19 500	1 320	1 990	5 500	8 000	HK3012	—	0.024	IR25×30×12.5
	37	12	2.7	13 000	19 500	1 320	1 990	5 500	8 000	—	BK3012	0.028	IR25×30×12.5
	37	16	—	18 100	30 000	1 850	3 050	5 500	8 000	HK3016	—	0.032	IR25×30×17
	37	16	2.7	18 100	30 000	1 850	3 050	5 500	8 000	—	BK3016C	0.037	IR25×30×17
	37	20	—	22 300	39 500	2 280	4 000	5 500	8 000	HK3020	—	0.040	IR25×30×20.5
	37	20	2.7	22 300	39 500	2 280	4 000	5 500	8 000	—	BK3020	0.047	IR25×30×20.5
	37	26	—	28 500	54 000	2 910	5 500	5 500	8 000	HK3026	—	0.053	IR25×30×26.5
	37	26	2.7	29 100	55 000	2 960	5 650	5 500	8 000	—	BK3026	0.059	IR25×30×26.5
	37	38	—	38 500	78 500	3 900	8 000	5 500	8 000	HK3038ZWD	—	0.076	IR25×30×38.5
	37	38	2.7	38 500	78 500	3 900	8 000	5 500	8 000	—	BK3038ZWD	0.083	IR25×30×38.5
	40	13	—	14 100	17 100	1 430	1 750	5 500	8 000	HMK3013	—	0.040	IR25×30×16
	40	15	—	17 100	22 100	1 750	2 250	5 500	8 000	HMK3015	—	0.044	IR25×30×16
	40	20	—	24 200	34 500	2 470	3 500	5 500	8 000	HMK3020	—	0.058	IR25×30×20.5
	40	25	—	31 000	47 000	3 150	4 800	5 500	8 000	HMK3025	—	0.073	IR25×30×26.5

Note 1) Bearing with inner ring is represented by HK+IR. (Refer to "Inner Ring Dimensions Table" on page B-120.)
 EX. HK2820 + IR22×28×20.5

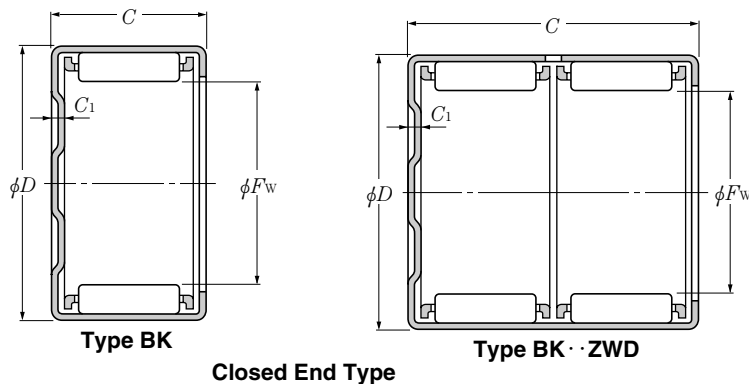

F_w 30~40mm

Boundary dimensions				Basic load ratings				Limiting speeds		Bearing numbers		Mass	Appropriate ¹⁾ inner ring
mm				N		kgf		r/min		open end design	closed end design	kg	(as a reference)
F_w	D	C 0 -0.2	C_1 max	C_r	C_{or}	C_r	C_{or}	grease	oil			(approx.)	
30	40	30	—	36 000	57 500	3 700	5 850	5 500	8 000	HMK3030	—	0.087	IR25×30×32
32	42	20	—	27 500	38 000	2 800	3 850	5 000	7 500	HMK3220	—	0.062	—
	42	30	—	41 500	64 500	4 250	6 550	5 000	7 500	HMK3230	—	0.092	—
35	42	12	—	14 000	22 800	1 430	2 320	4 700	7 000	HK3512	—	0.028	—
	42	12	2.7	14 000	22 800	1 430	2 320	4 700	7 000	—	BK3512	0.033	—
	42	16	—	19 700	35 000	2 000	3 600	4 700	7 000	HK3516	—	0.037	—
	42	16	2.7	19 700	35 000	2 000	3 600	4 700	7 000	—	BK3516	0.044	—
	42	20	—	24 800	47 500	2 530	4 850	4 700	7 000	HK3520	—	0.046	—
	42	20	2.7	24 800	47 500	2 530	4 850	4 700	7 000	—	BK3520	0.055	—
	45	12	—	14 900	17 600	1 520	1 800	4 700	7 000	HMK3512	—	0.040	—
	45	15	—	20 200	26 200	2 060	2 670	4 700	7 000	HMK3515	—	0.050	—
	45	20	—	28 400	40 500	2 890	4 100	4 700	7 000	HMK3520	—	0.067	—
	45	25	—	36 000	54 500	3 650	5 550	4 700	7 000	HMK3525	—	0.083	—
37	47	20	—	29 300	43 000	2 990	4 350	4 300	6 500	HMK3720	—	0.070	—
	47	30	—	44 500	73 000	4 550	7 450	4 300	6 500	HMK3730	—	0.105	—
38	48	15	—	21 700	29 300	2 210	2 990	4 300	6 500	HMK3815	—	0.054	—
	48	20	—	30 500	45 000	3 100	4 600	4 300	6 500	HMK3820	—	0.072	—
	48	25	—	38 500	61 000	3 900	6 250	4 300	6 500	HMK3825	—	0.090	—
	48	30	—	46 000	77 000	4 700	7 850	4 300	6 500	HMK3830	—	0.107	IR32×38×32
	48	45	—	62 000	113 000	6 300	11 500	4 300	6 500	HMK3845ZWD	—	0.161	—
40	47	12	—	15 100	26 000	1 540	2 660	4 000	6 000	HK4012	—	0.031	IR35×40×12.5
	47	12	2.7	15 100	26 000	1 540	2 660	4 000	6 000	—	BK4012	0.038	IR35×40×12.5
	47	16	—	21 100	40 000	2 150	4 100	4 000	6 000	HK4016	—	0.041	IR35×40×17
	47	16	2.7	21 100	40 000	2 150	4 100	4 000	6 000	—	BK4016	0.051	IR35×40×17
	47	20	—	25 900	52 500	2 650	5 350	4 000	6 000	HK4020	—	0.052	IR35×40×20.5
	47	20	2.7	25 900	52 500	2 650	5 350	4 000	6 000	—	BK4020	0.064	IR35×40×20.5
	50	15	—	23 100	32 500	2 350	3 300	4 000	6 000	HMK4015	—	0.056	IR35×40×17
	50	20	—	32 500	50 000	3 300	5 100	4 000	6 000	HMK4020	—	0.075	IR35×40×20.5
	50	25	—	41 000	67 500	4 150	6 900	4 000	6 000	HMK4025	—	0.094	—

Note 1) Bearing with inner ring is represented by HK+IR. (Refer to "Inner Ring Dimensions Table" on page B-121, B122.)
EX. HK4012 + IR35×40×12.5

Type HK

Type HMK, Type HMK··ZWD

Type BK

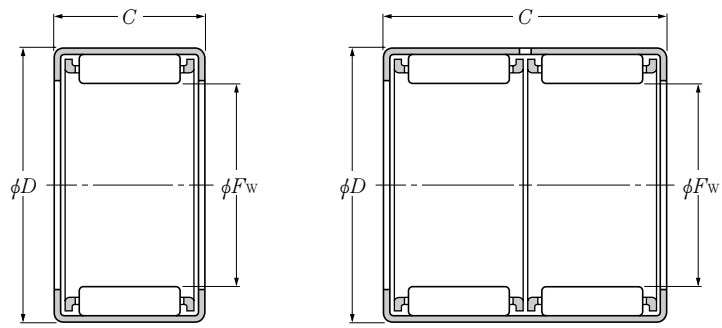

Type HK, Type HMK

Type HMK··ZWD

Opened End Type

 F_w 40~50mm

Boundary dimensions	Basic load ratings				Limiting speeds		Bearing numbers		Mass kg (approx.)	Appropriate ¹⁾ inner ring (as a reference)			
	mm				r/min		open end design	closed end design					
	F_w	D	C 0 -0.2	C_1 max	dynamic N	static kgf					grease	oil	
				C_r	C_{or}	C_r	C_{or}						
40	50	30	—	49 000	85 000	5 000	8 700	4 000	6 000	HMK4030	—	0.112	IR35×40×34
	50	40	—	58 500	107 000	5 950	10 900	4 000	6 000	HMK4040ZWD	—	0.150	—
45	52	16	—	21 600	43 000	2 210	4 400	3 700	5 500	HK4516	—	0.046	IR40×45×17
	52	16	2.7	21 600	43 000	2 210	4 400	3 700	5 500	—	BK4516	0.058	IR40×45×17
	52	20	—	27 600	59 000	2 810	6 000	3 700	5 500	HK4520	—	0.058	IR40×45×20.5
	52	20	2.7	27 600	59 000	2 810	6 000	3 700	5 500	—	BK4520	0.072	IR40×45×20.5
	55	20	—	33 000	53 000	3 350	5 400	3 700	5 500	HMK4520	—	0.083	IR40×45×20.5
	55	25	—	41 500	71 500	4 250	7 300	3 700	5 500	HMK4525	—	0.104	IR40×45×26.5
	55	30	—	49 500	90 000	5 050	9 150	3 700	5 500	HMK4530	—	0.125	IR40×45×34
	55	40	—	59 500	113 000	6 050	11 500	3 700	5 500	HMK4540ZWD	—	0.167	—
50	58	20	—	31 500	63 000	3 200	6 450	3 200	4 800	HK5020	—	0.072	IR40×50×22
	58	20	2.7	31 500	63 000	3 200	6 450	3 200	4 800	—	BK5020	0.087	IR40×50×22
	58	25	—	38 500	82 000	3 900	8 400	3 200	4 800	HK5025	—	0.090	IR45×50×25.5
	58	25	2.7	38 500	82 000	3 900	8 400	3 200	4 800	—	BK5025	0.109	IR45×50×25.5
	62	12	—	18 200	23 600	1 860	2 410	3 200	4 800	HMK5012	—	0.067	—
	62	15	—	25 900	37 000	2 650	3 800	3 200	4 800	HMK5015	—	0.084	—
	62	20	—	37 500	60 000	3 850	6 100	3 200	4 800	HMK5020	—	0.112	IR40×50×22
	62	25	—	48 000	82 500	4 900	8 450	3 200	4 800	HMK5025	—	0.140	IR45×50×25.5
	62	30	—	58 500	105 000	5 950	10 700	3 200	4 800	HMK5030B	—	0.168	IR45×50×32
	62	40	—	70 000	134 000	7 150	13 600	3 200	4 800	HMK5040ZWD	—	0.224	—
62	45	—	79 000	156 000	8 050	15 900	3 200	4 800	HMK5045ZWB	—	0.252	—	

Note 1) Bearing with inner ring is represented by HK+IR. (Refer to "Inner Ring Dimensions Table" on page B-122, B123.)
EX. HK4516 + IR40×45×17

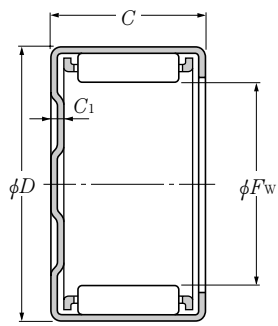

Type BK
Closed End Type

- Type HK··L
- Type HMK··L
- Type HK··LL
- Type HMK··LL
- Type BK··L

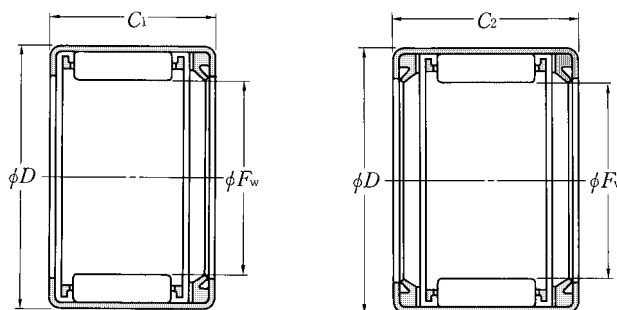

Type HK··L, Type HMK··L (Opened end and single-side seal type) **Type HK··LL, Type HMK··LL** (Opened end and double-side seal type)

F_w 8~25mm

Boundary dimensions					Basic load ratings				Limiting speeds r/min grease	Bearing numbers		
F_w	D	C_1 mm 0 -0.2	C_2 mm 0 -0.2	C_3 max	dynamic N	static	dynamic kgf	static		open end single seal	open end double seal	closed end single seal
					C_r	C_{or}	C_r	C_{or}				
8	15	12	14	—	3 800	2 870	390	293	10 000	HMK0812L	HMK0814LL	—
10	17	12	14	—	4 250	3 450	435	350	10 000	HMK1012L	HMK1014LL	—
12	18	14	16	2.7	6 600	7 300	675	745	10 000	HK 1214L	HK 1216LL	BK1214L
	19	14	16	—	7 100	6 900	725	705	10 000	HMK1214L	HMK1216LL	—
14	20	14	16	2.7	7 200	8 500	735	865	10 000	HK 1414L	HK 1416LL	BK1414L
	22	19	22	—	11 500	12 000	1 180	1 220	10 000	HMK1419L	HMK1422LL	—
15	21	14	16	2.7	7 500	9 100	765	930	10 000	HK 1514L	HK 1516LL	BK1514L
	22	13	16	—	6 100	6 000	620	610	10 000	HMK1513L	HMK1516LL	—
	22	18	21	—	10 900	12 700	1 120	1 300	10 000	HMK1518L	HMK1521LL	—
16	22	14	16	2.7	7 750	9 700	795	990	10 000	HK 1614L	HK 1616LL	BK1614L
	24	23	26	—	15 600	18 200	1 590	1 860	10 000	HMK1623L	HMK1626LL	—
17	24	18	21	—	12 100	15 000	1 230	1 530	9 500	HMK1718L	HMK1721LL	—
18	24	14	16	2.7	8 300	10 900	845	1 110	9 000	HK 1814L	HK 1816LL	BK1814L
	25	18	21	—	12 000	15 100	1 220	1 540	9 000	HMK1818L	HMK1821LL	—
	25	20	23	—	13 800	18 000	1 400	1 830	9 000	HMK1820L	HMK1823LL	—
19	27	19	22	—	13 900	16 300	1 410	1 660	8 500	HMK1919L	HMK1922LL	—
20	26	—	16	—	9 250	13 000	945	1 330	8 000	—	HK 2016LL	—
	26	18	20	2.7	13 000	20 100	1 320	2 050	8 000	HK 2018L	HK 2020LL	BK2018L
	27	18	21	—	13 000	17 300	1 330	1 760	8 000	HMK2018L	HMK2021LL	—
	27	23	26	—	17 700	25 600	1 800	2 610	8 000	HMK2023L	HMK2026LL	—
22	28	—	16	—	9 750	14 300	995	1 460	7 500	—	HK 2216LL	—
	28	18	20	2.7	13 600	22 100	1 390	2 250	7 500	HK 2218L	HK 2220LL	BK2218L
	29	18	21	—	13 400	18 500	1 370	1 890	7 500	HMK2218L	HMK2221LL	—
	29	23	26	—	18 200	27 400	1 860	2 790	7 500	HMK2223L	HMK2226LL	—
24	31	23	26	—	18 800	29 100	1 910	2 970	6 500	HMK2423L	HMK2426LL	—
25	32	—	16	—	11 800	16 300	1 200	1 660	6 500	—	HK 2516LL	—
	32	18	20	2.7	15 900	24 000	1 620	2 450	6 500	HK 2518L	HK 2520LL	BK2518L

Note 1) Bearing with inner ring is represented by HK+IR. (Refer to "Inner Ring Dimensions Table" on page B-117 to B119.)
EX. HK1416LL + IR10×14×20

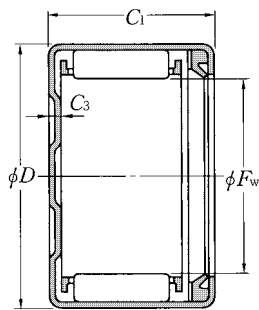

Type BK·L
(Closed end and single-side seal type)

open end single seal	Mass kg (approx.)		Appropriate ¹⁾ inner ring (as a reference)	
	open end double seal	closed end single seal	single seal	double seal
0.0071	0.0075	—	IR 5×8×16	IR 5× 8×16
0.0084	0.0089	—	IR 7×10×16	IR 7×10×16
0.011	0.0120	0.012	IR 9×12×16	—
0.011	0.0120	—	IR 9×12×16	—
0.012	0.0140	0.014	IR10×14×16	IR10×14×20
0.020	0.0210	—	IR10×14×20	—
0.013	0.0140	0.014	IR12×15×16.5	IR12×15×16.5
0.014	0.0150	—	IR12×15×16	IR12×15×16.5
0.017	0.0180	—	IR12×15×22.5	IR12×15×22.5
0.013	0.0150	0.015	IR12×16×16	IR12×16×20
0.028	0.0290	—	—	—
0.019	0.0200	—	IR12×17×20.5	IR12×17×25.5
0.015	0.0170	0.017	IR15×18×16	IR15×18×17.5
0.020	0.0210	—	IR15×18×20.5	IR15×18×25.5
0.023	0.0240	—	IR15×18×20.5	IR15×18×25.5
0.027	0.0290	—	IR15×19×20	—
—	0.0190	—	—	IR15×20×18
0.021	0.0240	0.024	IR17×20×20	IR17×20×20.5
0.022	0.0240	—	IR17×20×20	IR15×20×23
0.029	0.0310	—	IR15×20×26	IR17×20×30.5
—	0.0200	—	—	IR17×22×18
0.024	0.0260	0.027	IR17×22×20.5	IR17×22×23
0.024	0.0260	—	IR17×22×20.5	IR17×22×23
0.032	0.0330	—	IR17×22×26	—
0.035	0.0370	—	—	IR20×24×28.5
—	0.0270	—	—	IR20×25×18D
0.031	0.0330	0.035	IR20×25×20	IR20×25×23

- Type HK··L
- Type HMK··L
- Type HK··LL
- Type HMK··LL
- Type BK··L

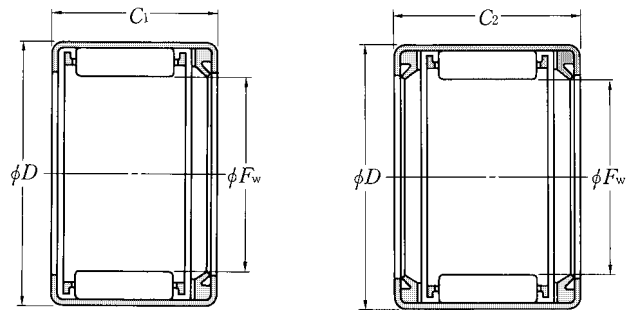

Type HK··L, Type HMK··L (Opened end and single-side seal type) **Type HK··LL, Type HMK··LL** (Opened end and double-side seal type)

F_w 25~50mm

Boundary dimensions					Basic load ratings				Limiting speeds r/min grease	Bearing numbers		
F_w	D	C_1 mm 0 -0.2	C_2 mm 0 -0.2	C_3 max	dynamic N	static N	dynamic kgf	static kgf		open end single seal	open end double seal	closed end single seal
					C_r	C_{or}	C_r	C_{or}				
25	33	18	21	—	15 800	21 000	1 610	2 140	6 500	HMK2518L	HMK2521LL	—
	33	23	26	—	21 800	31 500	2 220	3 200	6 500	HMK2523L	HMK2526LL	—
28	35	—	20	—	17 300	27 600	1 760	2 820	5 500	—	HK 2820LL	—
	37	23	26	—	23 600	32 500	2 410	3 350	5 500	HMK2823L	HMK2826LL	—
30	37	—	16	—	13 000	19 500	1 320	1 990	5 500	—	HK 3016LL	—
	37	18	20	2.7	18 100	30 000	1 850	3 050	5 500	HK 3018L	HK 3020LL	BK3018L
	40	23	26	—	24 200	34 500	2 470	3 500	5 500	HMK3023L	HMK3026LL	—
	40	28	31	—	31 000	47 000	3 150	4 800	5 500	HMK3028L	HMK3031LL	—
32	42	23	26	—	27 500	38 000	2 800	3 850	5 000	HMK3223L	HMK3226LL	—
35	42	—	16	—	14 000	22 800	1 430	2 320	4 600	—	HK 3516LL	—
	42	18	20	2.7	19 700	35 000	2 000	3 600	4 600	HK 3518L	HK 3520LL	BK3518L
	45	18	21	—	20 200	26 200	2 060	2 670	4 600	HMK3518L	HMK3521LL	—
	45	28	31	—	36 000	54 500	3 650	5 550	4 600	HMK3528L	HMK3531LL	—
38	48	28	31	—	38 500	61 000	3 900	6 250	4 200	HMK3828L	HMK3831LL	—
40	47	—	16	—	15 100	26 000	1 540	2 660	4 000	—	HK 4016LL	—
	47	18	20	2.7	21 100	40 000	2 150	4 100	4 000	HK 4018L	HK 4020LL	BK4018L
	50	18	21	—	23 100	32 500	2 350	3 300	4 000	HMK4018L	HMK4021LL	—
	50	28	31	—	41 000	67 500	4 150	6 900	4 000	HMK4028L	HMK4031LL	—
45	52	18	20	2.7	21 600	43 000	2 210	4 400	3 600	HK 4518L	HK 4520LL	BK4518L
	55	23	26	—	33 000	53 000	3 350	5 400	3 600	HMK4523L	HMK4526LL	—
50	58	22	24	2.7	31 500	63 000	3 200	6 450	3 200	HK 5022L	HK 5024LL	BK5022L
	62	28	31	—	48 000	82 500	4 900	8 450	3 200	HMK5028L	HMK5031LL	—

Note 1) Bearing with inner ring is represented by HK+IR. (Refer to "Inner Ring Dimensions Table" on page B-119 to B123.)
EX. HK5022L + IR45×50×25

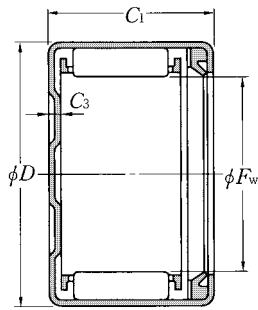

Type BK·L
(Closed end and single-side seal type)

	Mass kg (approx.)		Appropriate ¹⁾ inner ring (as a reference)	
	open end single seal	open end double seal	closed end single seal	single seal
0.031	0.034	—	IR20×25×20	IR20×25×23
0.041	0.043	—	IR20×25×26.5	IR20×25×26.5
—	0.037	—	—	IR22×28×23
0.051	0.054	—	—	IR22×28×30
—	0.027	—	—	IR25×30×18D
0.037	0.039	0.045	IR25×30×20	IR25×30×23
0.061	0.064	—	IR25×30×26	IR25×30×26.5
0.076	0.078	—	IR25×30×30	IR25×30×32
0.065	0.069	—	—	IR28×32×30
—	0.036	—	—	—
0.037	0.040	0.047	—	—
0.053	0.056	—	—	—
0.086	0.089	—	—	—
0.094	0.098	—	IR32×38×32	IR32×38×32
—	0.041	—	—	IR35×40×17
0.047	0.050	0.062	IR35×40×20	—
0.060	0.063	—	IR35×40×20	—
0.097	0.100	—	IR35×40×30	IR32×40×36
0.054	0.057	0.072	IR40×45×20	—
0.087	0.091	—	IR40×45×26.5	IR40×45×26.5
0.086	0.089	0.104	IR45×50×25	IR45×50×25.5
0.144	0.149	—	IR45×50×32	IR45×50×32

Inch series

Type DCL

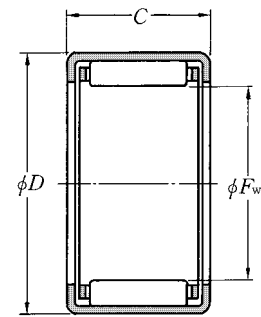

F_w 6.350~15.875mm

F_w	Boundary dimensions mm ($\frac{1}{25.4}$ mm)		Basic load ratings				Limiting speeds		Bearing numbers	Mass kg (approx.)	Appropriate ¹⁾ inner ring (as a reference)
	D	C -0.2	dynamic N C_r	static N C_{or}	dynamic kgf C_r	static kgf C_{or}	grease r/min	oil r/min			
6.350 ($\frac{1}{4}$)	11.112($\frac{7}{16}$)	6.350($\frac{1}{4}$)	1 580	1 110	161	113	25 000	38 000	DCL 44T2	0.0022	—
	11.112($\frac{7}{16}$)	7.938($\frac{5}{16}$)	2 160	1 670	221	170	25 000	38 000	DCL 45T2	0.0033	—
	11.112($\frac{7}{16}$)	11.112($\frac{7}{16}$)	3 550	3 150	360	320	25 000	38 000	DCL 47T2	0.0038	—
7.938 ($\frac{5}{16}$)	12.700($\frac{1}{2}$)	7.938($\frac{5}{16}$)	2 940	2 610	300	266	20 000	30 000	DCL 55	0.0032	—
	12.700($\frac{1}{2}$)	9.525($\frac{3}{8}$)	3 900	3 750	400	385	20 000	30 000	DCL 56	0.0039	—
	12.700($\frac{1}{2}$)	11.112($\frac{7}{16}$)	4 800	4 950	490	505	20 000	30 000	DCL 57	0.0048	—
	12.700($\frac{1}{2}$)	14.288($\frac{9}{16}$)	6 500	7 250	665	740	20 000	30 000	DCL 59	0.0058	—
9.525 ($\frac{3}{8}$)	14.288($\frac{9}{16}$)	7.938($\frac{5}{16}$)	3 100	2 910	315	297	17 000	25 000	DCL 65	0.0037	—
	14.288($\frac{9}{16}$)	9.525($\frac{3}{8}$)	4 100	4 200	420	430	17 000	25 000	DCL 66	0.0045	—
	14.288($\frac{9}{16}$)	12.700($\frac{1}{2}$)	5 900	6 650	600	675	17 000	25 000	DCL 68	0.0065	—
	14.288($\frac{9}{16}$)	15.875($\frac{5}{8}$)	7 500	9 050	765	925	17 000	25 000	DCL 610	0.0075	—
11.112 ($\frac{7}{16}$)	15.875($\frac{5}{8}$)	12.700($\frac{1}{2}$)	6 450	7 800	660	795	15 000	22 000	DCL 78	0.0068	—
12.700 ($\frac{1}{2}$)	17.462($\frac{11}{16}$)	7.938($\frac{5}{16}$)	3 550	3 700	360	380	13 000	19 000	DCL 85	0.0047	—
	17.462($\frac{11}{16}$)	9.525($\frac{3}{8}$)	4 700	5 350	480	550	13 000	19 000	DCL 86	0.0057	—
	17.462($\frac{11}{16}$)	11.112($\frac{7}{16}$)	5 800	7 050	590	715	13 000	19 000	DCL 87	0.0066	—
	17.462($\frac{11}{16}$)	12.700($\frac{1}{2}$)	6 700	8 500	685	865	13 000	19 000	DCL 88	0.0080	—
	17.462($\frac{11}{16}$)	15.875($\frac{5}{8}$)	8 550	11 600	870	1 180	13 000	19 000	DCL 810	0.0095	—
	17.462($\frac{11}{16}$)	19.050($\frac{3}{4}$)	10 400	14 900	1 060	1 520	13 000	19 000	DCL 812	0.0120	—
14.288 ($\frac{9}{16}$)	19.050($\frac{3}{4}$)	7.938($\frac{5}{16}$)	3 800	4 250	390	430	11 000	17 000	DCL 95	0.0052	—
	19.050($\frac{3}{4}$)	9.525($\frac{3}{8}$)	5 050	6 150	515	625	11 000	17 000	DCL 96	0.0063	MI-060908
	19.050($\frac{3}{4}$)	11.112($\frac{7}{16}$)	6 250	8 000	635	815	11 000	17 000	DCL 97	0.0073	MI-060908
	19.050($\frac{3}{4}$)	12.700($\frac{1}{2}$)	7 200	9 650	735	985	11 000	17 000	DCL 98	0.0086	MI-060908
	19.050($\frac{3}{4}$)	15.875($\frac{5}{8}$)	9 200	13 200	935	1 350	11 000	17 000	DCL 910	0.0110	—
	19.050($\frac{3}{4}$)	19.050($\frac{3}{4}$)	11 200	17 000	1 140	1 730	11 000	17 000	DCL 912	0.0130	—
15.875 ($\frac{5}{8}$)	20.638($\frac{13}{16}$)	7.938($\frac{5}{16}$)	4 050	4 750	415	485	10 000	15 000	DCL 105	0.0075	—
	20.638($\frac{13}{16}$)	11.112($\frac{7}{16}$)	6 650	9 000	680	915	10 000	15 000	DCL 107	0.0080	—
	20.638($\frac{13}{16}$)	12.700($\frac{1}{2}$)	7 700	10 800	785	1 110	10 000	15 000	DCL 108	0.0091	—
	20.638($\frac{13}{16}$)	15.875($\frac{5}{8}$)	9 800	14 800	1 000	1 510	10 000	15 000	DCL1010	0.0130	MI-061012
	20.638($\frac{13}{16}$)	19.050($\frac{3}{4}$)	11 900	19 000	1 220	1 940	10 000	15 000	DCL1012	0.0140	MI-061012

Note 1) Bearing with inner ring is represented by DCL-MI. (Refer to Inner Ring Dimension Table on page B-129.)
EX. DCL96 + MI-060908

Remarks: Manufacture of the closed end type bearings under this Table is also available.

F_w 15.875~25.400mm

Boundary dimensions			Basic load ratings				Limiting speeds		Bearing numbers	Mass kg (approx.)	Appropriate ¹⁾ inner ring (as a reference)	
mm ($\frac{1}{25.4}$ mm)			dynamic	static	dynamic	static	r/min					
F_w	D	C 0 -0.2	N		kgf		grease	oil				
			C_r	C_{or}	C_r	C_{or}						
15.875($\frac{5}{8}$)	20.638($\frac{13}{16}$)	22.225($\frac{7}{8}$)	14 100	23 500	1 430	2 400	10 000	15 000	DCL1014	0.0160	MI-061016	
		22.225($\frac{7}{8}$)	5 700	7 650	585	780	9 500	14 000	DCL 116	0.0075	—	
	17.462($\frac{11}{16}$)	22.225($\frac{7}{8}$)	12.700($\frac{1}{2}$)	8 150	12 000	830	1 230	9 500	14 000	DCL 118	0.0110	—
		22.225($\frac{7}{8}$)	15.875($\frac{5}{8}$)	10 400	16 400	1 060	1 680	9 500	14 000	DCL1110	0.0130	—
		22.225($\frac{7}{8}$)	19.050($\frac{3}{4}$)	12 600	21 100	1 290	2 150	9 500	14 000	DCL1112	0.0160	—
19.050($\frac{3}{4}$)	25.400(1)	9.525($\frac{3}{8}$)	6 450	6 950	660	705	8 500	13 000	DCL 126	0.0110	—	
		12.700($\frac{1}{2}$)	9 800	11 900	1 000	1 210	8 500	13 000	DCL 128	0.0140	MI-081210	
		15.875($\frac{5}{8}$)	12 900	16 800	1 310	1 720	8 500	13 000	DCL1210	0.0170	MI-081210	
		19.050($\frac{3}{4}$)	15 900	22 100	1 620	2 250	8 500	13 000	DCL1212	0.0210	MI-081212	
		22.225($\frac{7}{8}$)	19 000	27 700	1 930	2 830	8 500	13 000	DCL1214	0.0260	MI-081216	
		25.400(1)	21 700	33 000	2 210	3 350	8 500	13 000	DCL1216	0.0300	MI-081216	
20.638($\frac{13}{16}$)	26.988($1\frac{1}{16}$)	9.525($\frac{3}{8}$)	6 950	7 800	710	795	8 000	12 000	DCL 136	0.0120	—	
		12.700($\frac{1}{2}$)	10 600	13 400	1 080	1 370	8 000	12 000	DCL 138	0.0160	—	
		15.875($\frac{5}{8}$)	13 900	19 000	1 410	1 930	8 000	12 000	DCL1310	0.0200	—	
		19.050($\frac{3}{4}$)	17 100	24 900	1 750	2 540	8 000	12 000	DCL1312	0.0230	—	
		22.225($\frac{7}{8}$)	20 400	31 500	2 080	3 200	8 000	12 000	DCL1314	0.0280	—	
		25.400(1)	23 400	37 000	2 380	3 800	8 000	12 000	DCL1316	0.0320	—	
		31.750($1\frac{1}{4}$)	29 000	49 000	2 960	5 000	8 000	12 000	DCL1320	0.0400	—	
22.225($\frac{7}{8}$)	28.575($1\frac{1}{8}$)	9.525($\frac{3}{8}$)	7 150	8 300	730	845	7 500	11 000	DCL 146	0.0130	MI-101406	
		12.700($\frac{1}{2}$)	10 900	14 200	1 110	1 450	7 500	11 000	DCL 148	0.0170	MI-101408	
		19.050($\frac{3}{4}$)	17 600	26 400	1 800	2 700	7 500	11 000	DCL1412	0.0250	MI-101412	
		22.225($\frac{7}{8}$)	21 000	33 000	2 140	3 400	7 500	11 000	DCL1414	0.0340	MI-101416	
		25.400(1)	24 100	39 500	2 450	4 000	7 500	11 000	DCL1416	0.0340	MI-101416	
23.812($\frac{15}{16}$)	30.162($1\frac{3}{16}$)	15.875($\frac{5}{8}$)	14 600	21 300	1 490	2 170	6 500	10 000	DCL1510	0.0230	—	
		25.400(1)	24 700	41 500	2 520	4 250	6 500	10 000	DCL1516	0.0360	—	
25.400(1)	31.750($1\frac{1}{4}$)	9.525($\frac{3}{8}$)	7 550	9 250	770	940	6 500	9 500	DCL 166	0.0140	—	
		12.700($\frac{1}{2}$)	11 500	15 800	1 170	1 610	6 500	9 500	DCL 168	0.0190	—	
		19.050($\frac{3}{4}$)	18 600	29 500	1 890	3 000	6 500	9 500	DCL1612	0.0310	MI-121612	
		22.225($\frac{7}{8}$)	22 100	37 000	2 260	3 750	6 500	9 500	DCL1614	0.0340	MI-121616	

Note 1) Bearing with inner ring is represented by DCL-MI. (Refer to Inner Ring Dimension Table on page B-129.)
EX. DCL128 + MI-081210

Remarks: Manufacture of the closed end type bearings under this Table is also available.

Inch series

Type DCL

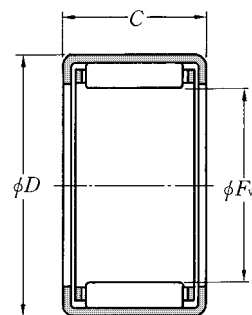

F_w 25.400~41.275mm

F_w	Boundary dimensions		Basic load ratings				Limiting speeds		Bearing numbers	Mass kg (approx.)	Appropriate ¹⁾ inner ring (as a reference)
	mm ($\frac{1}{16}$ mm)		dynamic	static	dynamic	static	r/min				
	D	C -0.2	N		kgf		grease	oil			
C_r	C_{or}	C_r	C_{or}								
25.400(1)	31.750(1 $\frac{1}{4}$)	25.400(1)	25 400	44 000	2 590	4 500	6 500	9 500	DCL1616	0.038	MI-121616
	31.750(1 $\frac{1}{4}$)	31.750(1 $\frac{1}{4}$)	31 500	58 000	3 200	5 900	6 500	9 500	DCL1620	0.048	—
26.988(1 $\frac{1}{16}$)	33.338(1 $\frac{5}{16}$)	15.875($\frac{5}{8}$)	15 900	24 600	1 620	2 510	6 000	9 000	DCL1710	0.025	—
28.575(1 $\frac{1}{8}$)	34.925(1 $\frac{3}{8}$)	9.525($\frac{3}{8}$)	8 150	10 600	830	1 080	5 500	8 500	DCL 186	0.016	MI-141808
	34.925(1 $\frac{3}{8}$)	12.700($\frac{1}{2}$)	12 400	18 200	1 260	1 850	5 500	8 500	DCL 188	0.021	MI-141808
	34.925(1 $\frac{3}{8}$)	19.050($\frac{3}{4}$)	20 100	34 000	2 050	3 450	5 500	8 500	DCL1812	0.032	MI-141812
	34.925(1 $\frac{3}{8}$)	25.400(1)	27 400	50 500	2 790	5 150	5 500	8 500	DCL1816	0.043	MI-141816
	34.925(1 $\frac{3}{8}$)	31.750(1 $\frac{1}{4}$)	34 000	66 500	3 450	6 800	5 500	8 500	DCL1820	0.053	MI-141820
30.162(1 $\frac{3}{16}$)	38.100(1 $\frac{1}{2}$)	25.400(1)	33 000	54 000	3 350	5 500	5 500	8 000	DCL1916	0.057	—
31.750(1 $\frac{1}{4}$)	38.100(1 $\frac{1}{2}$)	12.700($\frac{1}{2}$)	12 500	19 000	1 280	1 940	5 000	7 500	DCL 208	0.023	—
	38.100(1 $\frac{1}{2}$)	15.875($\frac{5}{8}$)	16 400	27 000	1 670	2 750	5 000	7 500	DCL2010	0.029	—
	38.100(1 $\frac{1}{2}$)	19.050($\frac{3}{4}$)	20 300	35 500	2 070	3 600	5 000	7 500	DCL2012	0.036	—
	38.100(1 $\frac{1}{2}$)	25.400(1)	27 700	53 000	2 830	5 400	5 000	7 500	DCL2016	0.047	—
	38.100(1 $\frac{1}{2}$)	31.750(1 $\frac{1}{4}$)	34 500	70 000	3 500	7 100	5 000	7 500	DCL2020	0.058	—
34.925(1 $\frac{3}{8}$)	41.275(1 $\frac{5}{8}$)	12.700($\frac{1}{2}$)	13 400	21 400	1 360	2 180	4 700	7 000	DCL 228	0.027	—
	41.275(1 $\frac{5}{8}$)	19.050($\frac{3}{4}$)	21 700	40 000	2 210	4 050	4 700	7 000	DCL2212	0.038	—
	41.275(1 $\frac{5}{8}$)	25.400(1)	29 600	59 500	3 000	6 050	4 700	7 000	DCL2216	0.051	—
	41.275(1 $\frac{5}{8}$)	31.750(1 $\frac{1}{4}$)	36 500	78 500	3 750	8 000	4 700	7 000	DCL2220	0.064	—
38.100(1 $\frac{1}{2}$)	47.625(1 $\frac{7}{8}$)	12.700($\frac{1}{2}$)	17 100	22 800	1 750	2 320	4 300	6 500	DCL 248	0.043	—
	47.625(1 $\frac{7}{8}$)	15.875($\frac{5}{8}$)	21 000	29 700	2 150	3 050	4 300	6 500	DCL2410	0.054	—
	47.625(1 $\frac{7}{8}$)	19.050($\frac{3}{4}$)	26 600	40 000	2 710	4 100	4 300	6 500	DCL2412	0.065	—
	47.625(1 $\frac{7}{8}$)	22.225($\frac{7}{8}$)	32 000	50 500	3 250	5 150	4 300	6 500	DCL2414	0.076	MI-202416
	47.625(1 $\frac{7}{8}$)	25.400(1)	36 500	60 500	3 750	6 200	4 300	6 500	DCL2416	0.087	MI-202416
	47.625(1 $\frac{7}{8}$)	31.750(1 $\frac{1}{4}$)	46 500	82 000	4 750	8 350	4 300	6 500	DCL2420	0.107	MI-202420
41.275(1 $\frac{5}{8}$)	50.800(2)	12.700($\frac{1}{2}$)	18 000	24 900	1 840	2 540	4 000	6 000	DCL 268	0.046	MI-222610
	50.800(2)	15.875($\frac{5}{8}$)	22 100	32 500	2 260	3 300	4 000	6 000	DCL2610	0.058	MI-222610
	50.800(2)	25.400(1)	38 500	66 500	3 950	6 800	4 000	6 000	DCL2616	0.106	—
	50.800(2)	31.750(1 $\frac{1}{4}$)	49 000	90 000	5 000	9 150	4 000	6 000	DCL2620	0.116	MI-212620

Note 1) Bearing with inner ring is represented by DCL-MI. (Refer to Inner Ring Dimension Table on page B-130.)
EX. DCL2414 + MI-202416

Remarks: Manufacture of the closed end type bearings under this Table is also available.

F_w 44.450~50.800mm

F_w	Boundary dimensions		Basic load ratings				Limiting speeds		Bearing numbers	Mass kg (approx.)	Appropriate ¹⁾ inner ring (as a reference)
	mm ($\frac{1}{25.4}$ mm)		dynamic	static	dynamic	static	r/min				
	D	C -0.2	N	N	kgf	kgf	grease	oil			
			C_r	C_{or}	C_r	C_{or}					
44.450(1 $\frac{3}{4}$)	53.975(2 $\frac{1}{8}$)	19.050($\frac{3}{4}$)	29 200	47 500	2 980	4 850	3 700	5 500	DCL2812	0.074	MI-242812
	53.975(2 $\frac{1}{8}$)	25.400(1)	40 500	72 000	4 100	7 350	3 700	5 500	DCL2816	0.099	MI-242816
	53.975(2 $\frac{1}{8}$)	38.100(1 $\frac{1}{2}$)	62 000	126 000	6 350	12 800	3 700	5 500	DCL2824	0.149	—
47.625(1 $\frac{7}{8}$)	57.150(2 $\frac{1}{4}$)	12.700($\frac{1}{2}$)	19 700	29 200	2 000	2 980	3 300	5 000	DCL 308	0.053	—
	57.150(2 $\frac{1}{4}$)	15.875($\frac{5}{8}$)	24 200	38 000	2 460	3 900	3 300	5 000	DCL3010	0.066	—
	57.150(2 $\frac{1}{4}$)	25.400(1)	42 000	78 000	4 300	7 950	3 300	5 000	DCL3016	0.106	—
50.800(2)	60.325(2 $\frac{3}{8}$)	12.700($\frac{1}{2}$)	20 400	31 500	2 080	3 200	3 100	4 700	DCL 328	0.056	—
	60.325(2 $\frac{3}{8}$)	25.400(1)	44 000	83 500	4 450	8 550	3 100	4 700	DCL3216	0.112	—
	60.325(2 $\frac{3}{8}$)	31.750(1 $\frac{1}{4}$)	55 500	113 000	5 650	11 500	3 100	4 700	DCL3220	0.140	—
	60.325(2 $\frac{3}{8}$)	38.100(1 $\frac{1}{2}$)	67 500	146 000	6 850	14 800	3 100	4 700	DCL3224	0.168	—

Note 1) Bearing with inner ring is represented by DCL-MI. (Refer to Inner Ring Dimension Table on page B-130.)
EX. DCL2816 + MI-242816

Remarks: Manufacture of the closed end type bearings under this Table is also available.

Type HCK

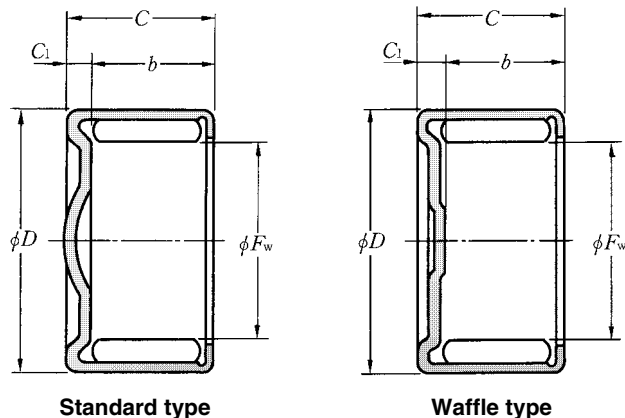

F_w 10~20mm

Boundary dimensions					Basic load ratings				Bearing numbers		Mass
mm					dynamic	static	dynamic	static	standard type	waffle type	kg
F_w	D	C	b	C_1	C_r	C_{or}	C_r	C_{or}			(approx.)
					N						
							kgf				
10	15	9.35	7.6	1.75	6 200	9 250	635	940	—	HCK1015	0.007
11.656	17.1	11.85	9.6	2.25	8 850	13 800	905	1 400	HCK1217	—	0.011
13	19	11.85	9.6	2.25	10 000	15 000	1 020	1 530	HCK1319	—	0.013
14	20	11.85	9.6	2.25	10 500	16 600	1 070	1 690	HCK1420	—	0.014
16	22	12.85	10.6	2.25	12 200	20 700	1 240	2 110	HCK1622	—	0.017
18	24	13.85	11.6	2.25	13 900	25 300	1 420	2 580	HCK1824	—	0.021
18	24.6	13.85	11.6	2.25	13 900	25 300	1 420	2 580	HCK1825	—	0.025
20	27.9	15.82	13.1	2.72	17 800	31 000	1 810	3 150	HCK2028	—	0.037