

Machined Ring Needle Roller Bearings



Machined Ring Needle Roller Bearings

The machined ring of this bearing type contains needle rollers and a cage. And the outer ring and the needle rollers are inseparable from each other by means of double-side ribs on the outer ring or side plates.

Because of its machined (solid) outer ring enabling to make it more rigid and to thereby upgrade the bearing accuracy, this bearing type is suitable for an application

requiring high speed, high load and high running accuracy. These machined ring needle roller bearings are available in two types -- one without inner ring and another with inner ring -- considering the case of using a shaft as the direct raceway surface without using inner ring.

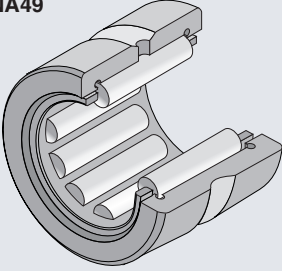
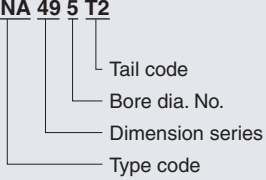
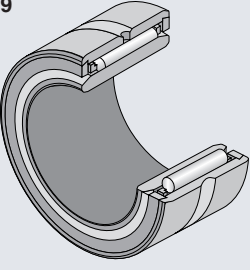
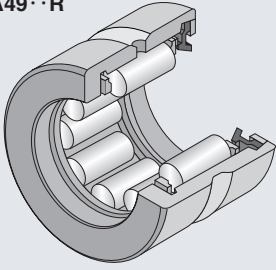
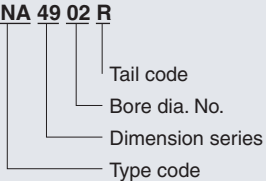
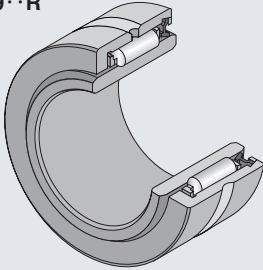
Bearing type	Applied shaft diameter (mm)	Composition of nominal bearing number	Remarks
Type RNA49 	$\phi 7 \sim \phi 12$	RNA 49 5 T2 	Bearing with tail code T2 uses a polyamide resin cage and, therefore, it shall be used at allowable temperature 120°C and, under continuous running, at 100°C and less.
Type NA49 	$\phi 5 \sim \phi 9$	[Tail code] T2: Resin cage	The dimension series is in compliance with JIS B 1512 or ISO 15.
Type RNA49 · R 	$\phi 14 \sim \phi 490$ With seal $\phi 14 \sim \phi 58$	RNA 49 02 R 	Bearing with seal type (Tail code: L or LL) - synthetic rubber seal built in at single side or double sides is internally filled up with lithium soap base grease.
Type NA49 · R 	$\phi 10 \sim \phi 440$ With seal $\phi 10 \sim \phi 50$	[Tail code] R: Rib type L: Single-side seal type LL: Double-side seal type	The sealed bearing type shall be used within the temperature range of -25 to 100°C to prevent deterioration of the seal and filled-up grease. The dimension series is in compliance with JIS B 15 or ISO 15.

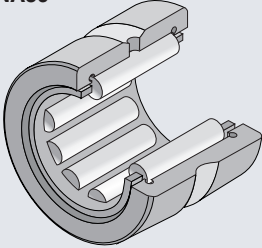
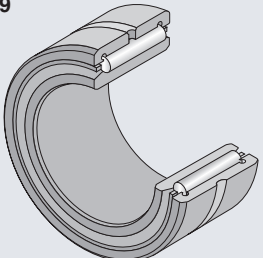
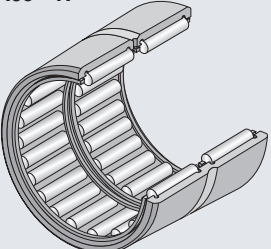
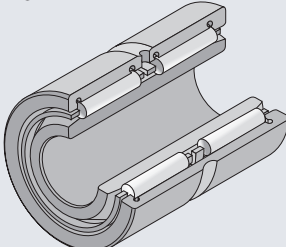
Bearing type	Applied shaft diameter (mm)	Composition of nominal bearing number	Remarks
Type RNA59 	$\phi 20 \sim \phi 160$	RNA 59 02 Type No. Dimension series Type code	The dimension series is in compliance with JIS B 1512 or ISO 15.
Type NA59 	$\phi 15 \sim \phi 140$	NA 59 / 22 Type No. Dimension series Type code	
Type RNA69 · R 	$\phi 16 \sim \phi 35$ $\phi 40 \sim \phi 110$ Built-in cage double-row type	RNA 69 01 R Tail code Type No. Dimension series Type code	
Type NA49 · R 	$\phi 12 \sim \phi 30$ $\phi 32 \sim \phi 95$ Built-in cage double-row type	NA 69 / 22 Type No. Dimension series Type code	

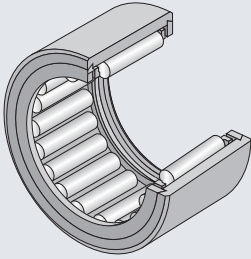
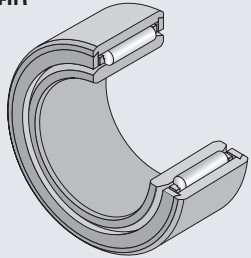
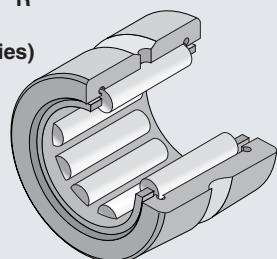
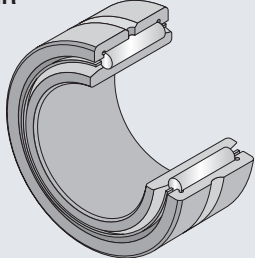
Bearing type	Applied shaft diameter (mm)	Composition of nominal bearing number	Remarks
Type NK 	$\phi 5 \sim \phi 12$	NK 7 / 10 T2 Type code — NK Inscribed circle diameter — 7 Width — 10 Tail code — T2	Bearing with tail code T2 uses a polyamide resin cage and, therefore, it shall be used at allowable temperature 120°C and, under continuous running, at 100°C and less.
Type NK+IR 	$\phi 5 \sim \phi 9$	NK24 / 16R + IR 20 × 24 × 16 Type code — NK Bore diameter — 24 Outer diameter — 16R Width — IR 20 × 24 × 16 [Tail code] R: Rib type T2: Resin cage	
Type NK · · R Type MR (Inch series) 	NK $\phi 14 \sim \phi 165$ MR $\phi 15.875 \sim \phi 234.95$	MR 10 18 12 Type code — MR Inscribed circle dia. code — 10 Outer diameter code — 18 Width code — 12	
NK · · Type R+IR Type MR+MI (Inch series) 	NK · · R+IR $\phi 10 \sim \phi 150$	MR101812 + MI - 06 10 12 Type code — MR Inscribed circle dia. code — 10 Outer diameter code — 18 Width code — 12 MI — 06 10 12	

Bearing Tolerances

The dimensional accuracy, profile accuracy and running accuracy of machined ring needle roller bearings are specified in JIS B 1514 (Accuracy of Rolling Bearings). (Refer to Section 4 "Bearing Tolerances", **Table 4.3** on page A-26.) Although the accuracy of NTN standard bearings conforms to JIS Class-0, NTN can also supply bearings conforming to JIS Class-6, -5 and -4.

Feel free to contact NTN for the further detail of these bearings.

The dimensional tolerances for the roller inscribed circle diameters (F_w) of bearing **type NK, RNA** and **MR** conform to ISO Tolerance Range Class-F6. Refer to this ISO Tolerance Class

in selecting shaft diameter and radial clearance.

Radial clearance and bearing fits

NTN machined ring needle roller bearings (with inner ring) are all manufactured within the radial clearance range specified in **Table 5.1** of Subsection 5.1 "Radial Clearance in Bearings" (page A-30). Because of the narrow non-interchangeable clearance range, the bearings shipped after adjusted to a specific non-interchangeable clearance must be installed with the clearance remained unchanged.

The respective dimensional tolerances for shaft and housing bore sizes on/in which bearing with inner ring is press-fitted are per **Table 6.3** of 6.4 "Recommended Bearing Fits" (page A-34) which specifies them according to load characteristic, load magnitude, and shaft and housing bore sizes. The profile accuracy and

surface roughness of shaft and housing to be applied are as specified in **Table 7.3** of 7.3 "Shaft and Housing Accuracy" (page A-39).

A shaft is used as the direct raceway surface for a bearing without inner ring and, in this case, the shaft diameter (raceway diameter) tolerance is per **Table 1** specifying the tolerances according to each running clearance. And K7 tolerance generally in broad use is applied as the dimensional tolerance for the housing bore. Feel free to contact NTN for application of housing bore tolerance other than K7.

For the profile accuracy, surface roughness and hardness of a shaft acting as the raceway surface, refer to **Table 7.4** of 7.4 "Raceway Surface Accuracy"(page A-39).

Table 1 Shaft diameter (raceway diameter) tolerance

Roller inscribed circle dia. F_w mm		Tolerance range class for shaft		
Over	incl.	Smaller than ordinary clearance	Ordinary class	Larger than ordinary clearance
	80	k5	h5	f6
80	160	k5	g5	f6
160	180	k5	g5	e6
180	200	j5	g5	e6
200	250	j5	f6	e6
250	315	h5	f6	e6
315	400	g5	f6	d6

Dimension of oil hole in outer ring

The outer ring is provided with an oil hole and an oil groove to facilitate oil lubrication to bearing. (but excluding Type NK with roller inscribed circle diameter (F_w) of 12mm and less.)

Table 2 shows the oil hole dimension every outer ring diameter.

Table 2 Oil hole dimension

Outer ring outer diameter		Oil hole dia. (mm)	Number of oil hole
Over	incl.		
—	20	2.0	1
20	40	2.5	1
40	80	3.0	1
80	200	3.5	1
200	350	4.0	1
350	—	5.0	1

Mounting relations

In the case of raceway with an oil hole, the bearing must be installed so the oil hole locates within the non-load area. In addition, any bearing with inner ring must be used within the allowable stroking value (s) (with the rollers retained within the effective contact length range of inner ring).

For the allowable stroking value (s), refer to Fig. 1 and applicable "Dimensions Table".

The inner ring and outer ring of machined ring needle roller bearing must be positioned in axial direction by shoulder or snap ring in this case. For the shoulder dimension and corner roundness (r_a) of the shaft and the housing are as specified in applicable "Dimensions Table".

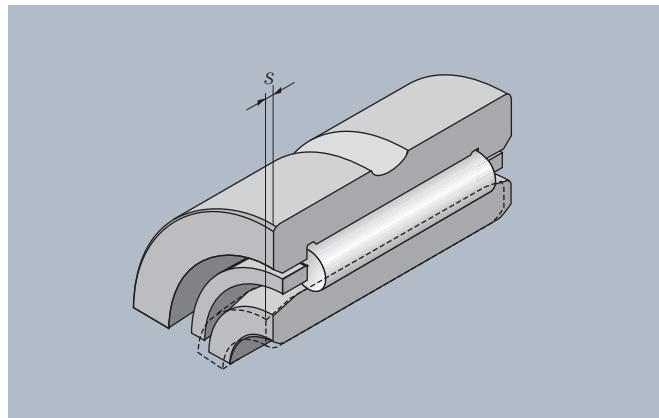
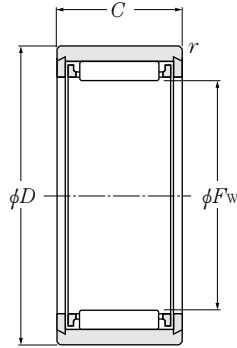

Fig. 1

Without Inner Ring

Type RNA49
Type RNA59
Type RNA69
Type NK



Type NK
($F_w \leq 12\text{mm}$)

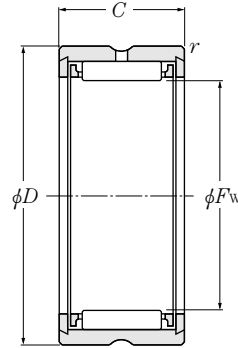

Type RNA49 ($F_w \leq 12\text{mm}$)

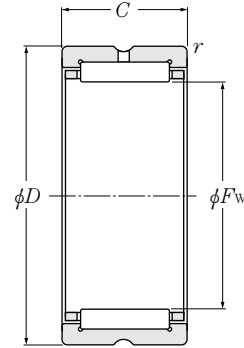

Type RNA49 · R ($F_w \geq 14\text{mm}$)
Type RNA59
Type RNA69 · R
Type NK · R ($F_w \geq 14\text{mm}$)

F_w 5~16mm

Boundary dimensions				Basic load ratings				Limiting speeds		Bearing numbers	Abutment dimensions		Mass kg (approx.)
mm				dynamic	static	dynamic	static	r/min			D_a	r_{as}	
F_w	D	C	$r_{s \min}^1)$	N	N	kgf	kgf	grease	oil	max	max		
5 $+0.018$ $+0.010$	10	10	0.15	2 640	2 190	269	224	27 000	40 000	NK5/10T2	6.5	0.15	0.0031
	10	12	0.15	2 720	2 250	277	230	27 000	40 000	NK5/12T2	6.5	0.15	0.0037
6 $+0.018$ $+0.010$	12	10	0.15	2 660	2 280	272	233	25 000	37 000	NK6/10T2	7.5	0.15	0.0047
	12	12	0.15	3 400	3 150	345	320	25 000	37 000	NK6/12T2	7.5	0.15	0.0057
7 $+0.022$ $+0.013$	13	10	0.15	2 670	2 350	272	239	23 000	34 000	RNA495T2	8.5	0.15	0.0055
	14	10	0.3	2 670	2 350	272	239	23 000	34 000	NK7/10T2	8.5	0.3	0.0069
	14	12	0.3	3 400	3 200	345	330	23 000	34 000	NK7/12T2	8.5	0.3	0.0082
8 $+0.022$ $+0.013$	15	10	0.15	3 150	3 000	320	305	21 000	32 000	RNA496	9.5	0.15	0.0073
	15	12	0.3	4 000	4 100	410	420	21 000	32 000	NK8/12T2	9.5	0.3	0.0087
	15	16	0.3	4 850	5 200	495	535	21 000	32 000	NK8/16T2	9.5	0.3	0.0120
9 $+0.022$ $+0.013$	16	12	0.3	4 550	5 000	465	510	20 000	30 000	NK9/12T2	10.5	0.3	0.0100
	16	16	0.3	5 500	6 400	560	650	20 000	30 000	NK9/16T2	10.5	0.3	0.0130
	17	10	0.15	3 600	3 650	365	375	20 000	30 000	RNA497	10.5	0.15	0.0095
10 $+0.022$ $+0.013$	17	12	0.3	4 550	5 100	460	520	19 000	28 000	NK10/12T2	11.5	0.3	0.0100
	17	16	0.3	5 450	6 450	555	660	19 000	28 000	NK10/16	11.5	0.3	0.0130
	19	11	0.15	4 300	3 950	435	405	19 000	28 000	RNA498	12	0.15	0.0130
12 $+0.027$ $+0.016$	19	12	0.3	5 000	6 100	510	620	17 000	26 000	NK12/12	13.5	0.3	0.0130
	19	16	0.3	6 000	7 700	615	785	17 000	26 000	NK12/16	13.5	0.3	0.0160
	20	11	0.3	4 850	4 900	495	500	17 000	26 000	RNA499	14	0.3	0.0130
14 $+0.027$ $+0.016$	22	13	0.3	8 600	9 200	875	935	16 000	24 000	RNA4900R	20	0.3	0.0170
	22	16	0.3	10 300	11 500	1 050	1 170	16 000	24 000	NK14/16R	20	0.3	0.0210
	22	20	0.3	13 000	15 600	1 330	1 590	16 000	24 000	NK14/20R	20	0.3	0.0260
15 $+0.027$ $+0.016$	23	16	0.3	10 900	12 700	1 110	1 290	15 000	23 000	NK15/16R	21	0.3	0.0220
	23	20	0.3	13 800	17 200	1 410	1 750	15 000	23 000	NK15/20R	21	0.3	0.0270
16 $+0.027$ $+0.016$	24	13	0.3	9 550	10 900	975	1 110	15 000	23 000	RNA4901R	22	0.3	0.0170
	24	16	0.3	12 200	14 900	1 240	1 520	15 000	23 000	NK16/16R	22	0.3	0.0220
	24	20	0.3	14 600	18 800	1 490	1 920	15 000	23 000	NK16/20R	22	0.3	0.0280
	24	22	0.3	15 400	20 000	1 570	2 040	15 000	23 000	RNA6901R	22	0.3	0.0310

Note 1) Allowable minimum chamfer dimension r .

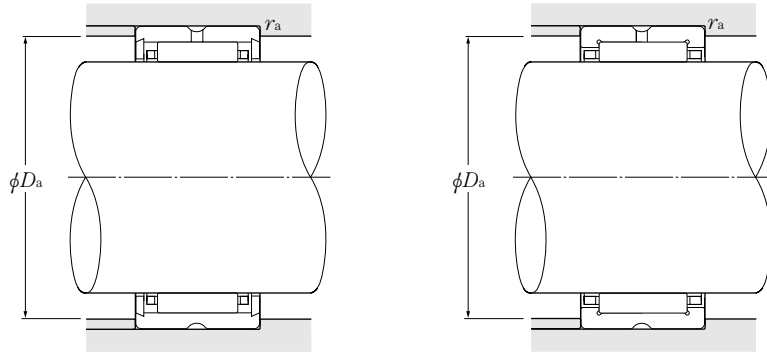

F_w 17~28mm

Boundary dimensions				Basic load ratings				Limiting speeds		Bearing numbers	Abutment dimensions		Mass kg (approx.)
mm				dynamic	static	dynamic	static	r/min			D_a	r_{as}	
F_w	D	C	r_s min ¹⁾	C_r	C_{or}	C_r	C_{or}	grease	oil		max	max	
17 ^{+0.027} _{+0.016}	25	16	0.3	12 100	15 000	1 240	1 530	15 000	22 000	NK17/16R	23	0.3	0.024
	25	20	0.3	15 400	20 400	1 570	2 080	15 000	22 000	NK17/20R	23	0.3	0.030
18 ^{+0.027} _{+0.016}	26	16	0.3	12 700	16 200	1 300	1 650	14 000	21 000	NK18/16R	24	0.3	0.025
	26	20	0.3	16 100	22 000	1 640	2 250	14 000	21 000	NK18/20R	24	0.3	0.031
19 ^{+0.033} _{+0.020}	27	16	0.3	13 300	17 400	1 350	1 780	14 000	21 000	NK19/16R	25	0.3	0.026
	27	20	0.3	16 000	22 200	1 630	2 260	14 000	21 000	NK19/20R	25	0.3	0.032
20 ^{+0.033} _{+0.020}	28	13	0.3	10 300	12 800	1 050	1 310	13 000	20 000	RNA4902R	26	0.3	0.022
	28	16	0.3	13 200	17 500	1 340	1 790	13 000	20 000	NK20/16R	26	0.3	0.027
	28	18	0.3	14 100	19 100	1 440	1 950	13 000	20 000	RNA5902	26	0.3	0.033
	28	20	0.3	16 700	23 800	1 700	2 420	13 000	20 000	NK20/20R	26	0.3	0.034
	28	23	0.3	17 600	25 300	1 790	2 580	13 000	20 000	RNA6902R	26	0.3	0.040
21 ^{+0.033} _{+0.020}	29	16	0.3	13 700	18 700	1 400	1 910	13 000	19 000	NK21/16R	27	0.3	0.028
	29	20	0.3	18 300	27 100	1 860	2 760	13 000	19 000	NK21/20R	27	0.3	0.035
22 ^{+0.033} _{+0.020}	30	16	0.3	14 200	19 900	1 450	2 030	12 000	18 000	NK22/16R	28	0.3	0.034
	30	20	0.3	18 000	27 000	1 840	2 760	12 000	18 000	NK22/20R	28	0.3	0.037
	30	13	0.3	11 200	14 600	1 140	1 490	12 000	18 000	RNA4903R	28	0.3	0.022
	30	18	0.3	15 200	21 700	1 550	2 210	12 000	18 000	RNA5903	28	0.3	0.035
	30	23	0.3	18 200	27 200	1 850	2 770	12 000	18 000	RNA6903R	28	0.3	0.042
24 ^{+0.033} _{+0.020}	32	16	0.3	15 200	22 300	1 550	2 280	11 000	170 00	NK24/16R	30	0.3	0.032
	32	20	0.3	18 600	28 800	1 890	2 930	11 000	17 000	NK24/20R	30	0.3	0.040
25 ^{+0.033} _{+0.020}	33	16	0.3	15 100	22 400	1 540	2 280	11 000	16 000	NK25/16R	31	0.3	0.033
	33	20	0.3	19 200	30 500	1 960	3 100	11 000	16 000	NK25/20R	31	0.3	0.042
	37	17	0.3	21 300	25 500	2 170	2 600	11 000	16 000	RNA4904R	35	0.3	0.052
	37	23	0.3	28 400	37 000	2 900	3 750	11 000	16 000	RNA5904	35	0.3	0.084
	37	30	0.3	36 500	50 500	3 700	5 150	11 000	16 000	RNA6904R	35	0.3	0.100
26 ^{+0.033} _{+0.020}	34	16	0.3	15 600	23 600	1 590	2 410	10 000	15 000	NK26/16R	32	0.3	0.034
	34	20	0.3	19 100	30 500	1 940	3 100	10 000	15 000	NK26/20R	32	0.3	0.042
28 ^{+0.033} _{+0.020}	37	20	0.3	22 300	34 000	2 280	3 450	9 500	14 000	NK28/20R	35	0.3	0.052
	37	30	0.3	26 700	48 000	2 720	4 900	9 500	14 000	NK28/30R	35	0.3	0.082

Note 1) Allowable minimum chamfer dimension r_s .

Without Inner Ring

Type RNA49
Type RNA59
Type RNA69
Type NK

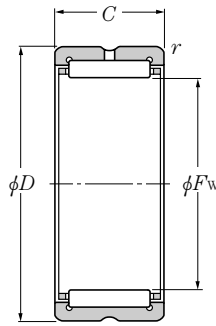

Type RNA49 · R
Type RNA59
Type RNA69 · R ($F_w \leq 35\text{mm}$)
Type NK · R

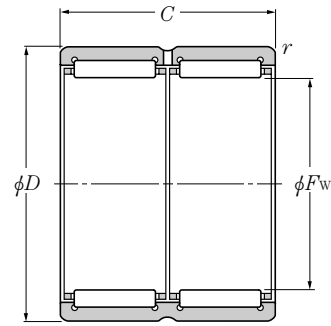

Type RNA69 · R ($F_w \geq 40\text{mm}$)

F_w 28~40mm

Boundary dimensions				Basic load ratings				Limiting speeds		Bearing numbers	Abutment dimensions		Mass kg (approx.)
mm				dynamic	static	dynamic	static	r/min			D_a	r_{as}	
F_w	D	C	$r_{s \min}^1)$	N		kgf		grease	oil	max	max		
28 ^{+0.033} _{+0.020}	39	17	0.3	23 200	29 300	2 360	2 990	9 500	14 000	RNA49/22R	37	0.3	0.050
	39	23	0.3	26 400	37 500	2 690	3 850	9 500	14 000	RNA59/22	37	0.3	0.092
	39	30	0.3	40 000	58 500	4 050	6 000	9 500	14 000	RNA69/22R	37	0.3	0.100
29 ^{+0.033} _{+0.020}	38	20	0.3	22 200	34 000	2 270	3 450	9 500	14 000	NK29/20R	36	0.3	0.054
	38	30	0.3	27 500	50 500	2 810	5 150	9 500	14 000	NK29/30R	36	0.3	0.084
30 ^{+0.033} _{+0.020}	40	20	0.3	22 100	34 000	2 260	3 500	8 500	13 000	NK30/20R	38	0.3	0.065
	40	30	0.3	33 000	57 000	3 350	5 800	8 500	13 000	NK30/30R	38	0.3	0.098
	42	17	0.3	24 000	31 500	2 450	3 200	8 500	13 000	RNA4905R	40	0.3	0.061
	42	23	0.3	30 500	43 000	3 150	4 350	8 500	13 000	RNA5905	40	0.3	0.101
	42	30	0.3	41 500	63 000	4 200	6 400	8 500	13 000	RNA6905R	40	0.3	0.112
32 ^{+0.041} _{+0.025}	42	20	0.3	23 500	37 500	2 400	3 850	8 500	13 000	NK32/20R	40	0.3	0.068
	42	30	0.3	34 000	60 500	3 450	6 150	8 500	13 000	NK32/30R	40	0.3	0.102
	45	17	0.3	24 800	33 500	2 530	3 400	8 500	13 000	RNA49/28R	43	0.3	0.073
	45	23	0.3	32 000	45 500	3 250	4 650	8 500	13 000	RNA59/28	43	0.3	0.108
	45	30	0.3	43 000	67 000	4 350	6 850	8 500	13 000	RNA69/28R	43	0.3	0.135
35 ^{+0.041} _{+0.025}	45	20	0.3	24 800	41 500	2 520	4 250	7 500	11 000	NK35/20R	43	0.3	0.074
	45	30	0.3	36 000	66 500	3 650	6 800	7 500	11 000	NK35/30R	43	0.3	0.112
	47	17	0.3	25 500	35 500	2 600	3 600	7 500	11 000	RNA4906R	45	0.3	0.069
	47	23	0.3	32 500	48 500	3 350	4 950	7 500	11 000	RNA5906	45	0.3	0.108
	47	30	0.3	42 500	67 500	4 300	6 900	7 500	11 000	RNA6906R	45	0.3	0.126
37 ^{+0.041} _{+0.025}	47	20	0.3	25 300	43 500	2 580	4 400	7 500	11 000	NK37/20R	45	0.3	0.077
	47	30	0.3	36 500	69 500	3 750	7 100	7 500	11 000	NK37/30R	45	0.3	0.107
38 ^{+0.041} _{+0.025}	48	20	0.3	25 900	45 000	2 640	4 600	7 500	11 000	NK38/20R	46	0.3	0.079
	48	30	0.3	37 500	73 000	3 850	7 400	7 500	11 000	NK38/30R	46	0.3	0.107
40 ^{+0.041} _{+0.025}	50	20	0.3	26 400	47 000	2 700	4 800	6 500	10 000	NK40/20R	48	0.3	0.083
	50	30	0.3	38 500	76 000	3 900	7 750	6 500	10 000	NK40/30R	48	0.3	0.125
	52	20	0.6	31 500	47 500	3 200	4 850	6 500	10 000	RNA49/32R	48	0.6	0.089
	52	27	0.6	38 000	61 000	3 850	6 250	6 500	10 000	RNA59/32	48	0.6	0.149
	52	36	0.6	47 500	82 000	4 850	8 350	6 500	10 000	RNA69/32R	48	0.6	0.162

Note 1) Allowable minimum chamfer dimension r .

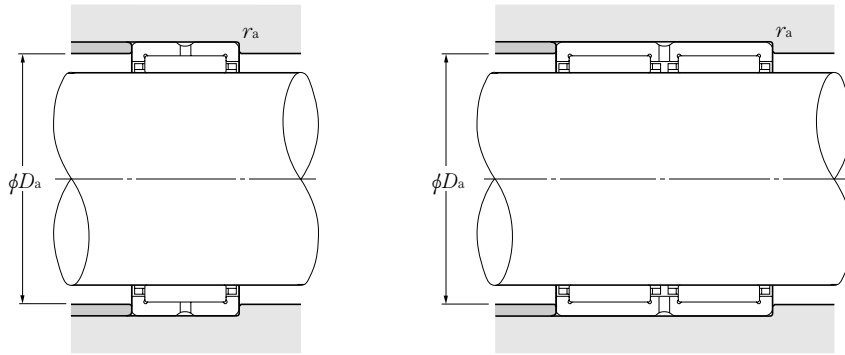

F_w 42~63mm

Boundary dimensions				Basic load ratings				Limiting speeds		Bearing numbers	Abutment dimensions		Mass kg (approx.)
mm				dynamic	static	dynamic	static	r/min			D_a	r_{as}	
F_w	D	C	r_s min ¹⁾	C_r	C_{or}	C_r	C_{or}	grease	oil		max	max	
42 ^{+0.041} _{+0.025}	52	20	0.3	26 900	49 000	2 750	5 000	6 500	9 500	NK42/20R	50	0.3	0.086
	52	30	0.3	39 000	79 000	4 000	8 050	6 500	9 500	NK42/30R	50	0.3	0.130
	55	20	0.6	32 000	50 000	3 300	5 100	6 500	9 500	RNA4907R	51	0.6	0.107
	55	27	0.6	39 000	64 500	3 950	6 550	6 500	9 500	RNA5907	51	0.6	0.176
	55	36	0.6	49 000	86 500	5 000	8 800	6 500	9 500	RNA6907R	51	0.6	0.193
43 ^{+0.041} _{+0.025}	53	20	0.3	27 500	51 000	2 810	5 200	6 500	9 500	NK43/20R	51	0.3	0.086
	53	30	0.3	40 000	82 000	4 100	8 400	6 500	9 500	NK43/30R	51	0.3	0.133
45 ^{+0.041} _{+0.025}	55	20	0.3	28 000	52 500	2 860	5 400	6 000	9 000	NK45/20R	53	0.3	0.092
	55	30	0.3	41 000	85 500	4 150	8 700	6 000	9 000	NK45/30R	53	0.3	0.139
47 ^{+0.041} _{+0.025}	57	20	0.3	28 800	55 500	2 940	5 650	5 500	8 500	NK47/20R	55	0.3	0.095
	57	30	0.3	42 500	91 500	4 350	9 350	5 500	8 500	NK47/30R	55	0.3	0.142
48 ^{+0.041} _{+0.025}	62	22	0.6	43 500	66 500	4 450	6 800	5 500	8 500	RNA4908R	58	0.6	0.140
	62	30	0.6	53 000	92 500	5 450	9 450	5 500	8 500	RNA5908	58	0.6	0.225
	62	40	0.6	67 000	116 000	6 850	11 800	5 500	8 500	RNA6908R	58	0.6	0.256
50 ^{+0.041} _{+0.025}	62	25	0.6	38 500	74 500	3 950	7 550	5 500	8 000	NK50/25R	58	0.6	0.158
	62	35	0.6	51 000	106 000	5 200	10 800	5 500	8 000	NK50/35R	58	0.6	0.221
52 ^{+0.049} _{+0.030}	68	22	0.6	46 000	73 000	4 700	7 450	5 000	7 500	RNA4909R	64	0.6	0.182
	68	30	0.6	56 000	101 000	5 700	10 300	5 000	7 500	RNA5909	64	0.6	0.232
	68	40	0.6	70 500	127 000	7 200	13 000	5 000	7 500	RNA6909R	64	0.6	0.273
55 ^{+0.049} _{+0.030}	68	25	0.6	41 000	82 000	4 150	8 400	5 000	7 500	NK55/25R	64	0.6	0.193
	68	35	0.6	54 000	118 000	5 500	12 000	5 000	7 500	NK55/35R	64	0.6	0.267
58 ^{+0.049} _{+0.030}	72	22	0.6	48 000	80 000	4 900	8 150	4 700	7 000	RNA4910R	68	0.6	0.163
	72	30	0.6	58 000	110 000	5 950	11 200	4 700	7 000	RNA5910	68	0.6	0.289
	72	40	0.6	74 000	139 000	7 500	14 200	4 700	7 000	RNA6910R	68	0.6	0.320
60 ^{+0.049} _{+0.030}	72	25	0.6	41 000	85 000	4 200	8 700	4 300	6 500	NK60/25R	68	0.6	0.185
	72	35	0.6	57 000	130 000	5 800	13 200	4 300	6 500	NK60/35R	68	0.6	0.258
63 ^{+0.049} _{+0.030}	80	25	1	58 500	99 500	6 000	10 100	4 300	6 500	RNA4911R	75	1	0.255
	80	34	1	76 500	140 000	7 800	14 300	4 300	6 500	RNA5911	75	1	0.367

Note 1) Allowable minimum chamfer dimension r_s .

Without Inner Ring

Type RNA49

Type RNA59

Type RNA69

Type NK

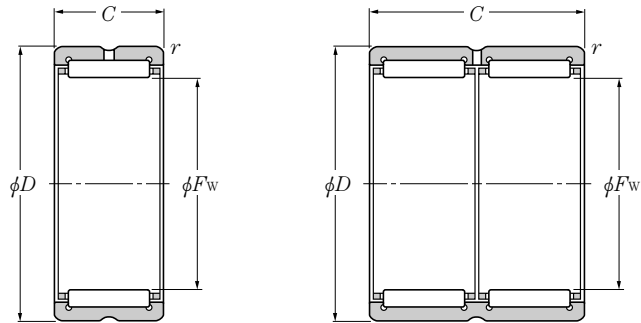

Type RNA48
Type RNA49 · R, Type RNA49
RNA59 type
Type NK · R, Type NK

Type RNA69 · R

F_w 63~85mm

Boundary dimensions				Basic load ratings				Limiting speeds		Bearing numbers	Abutment dimensions		Mass kg (approx.)
mm				dynamic	static	dynamic	static	r/min			D_a	r_{as}	
F_w	D	C	r_s min ¹⁾	C_r	C_{or}	C_r	C_{or}	grease	oil		max	max	
63 ^{+0.049} _{+0.030}	80	45	1	94 000	183 000	9 600	18 600	4 300	6 500	RNA6911R	75	1	0.470
65 ^{+0.049} _{+0.030}	78	25	0.6	45 000	98 000	4 550	10 000	4 000	6 000	NK65/25R	74	0.6	0.221
	78	35	0.6	60 000	142 000	6 100	14 400	4 000	6 000	NK65/35R	74	0.6	0.310
68 ^{+0.049} _{+0.030}	82	25	1	44 500	89 000	4 500	9 050	4 000	6 000	NK68/25R	77	0.6	0.241
	82	35	0.6	63 000	139 000	6 400	14 200	4 000	6 000	NK68/35R	78	0.6	0.338
	85	25	1	61 500	108 000	6 250	11 000	4 000	6 000	RNA4912R	80	1	0.275
	85	34	1	80 500	153 000	8 200	15 600	4 000	6 000	RNA5912	80	1	0.408
	85	45	1	95 500	191 000	9 750	19 400	4 000	6 000	RNA6912R	80	1	0.488
70 ^{+0.049} _{+0.030}	85	25	0.6	45 000	91 500	4 600	9 350	3 700	5 500	NK70/25R	81	0.6	0.275
	85	35	0.6	64 000	144 000	6 550	14 700	3 700	5 500	NK70/35R	81	0.6	0.386
72 ^{+0.049} _{+0.030}	90	25	1	62 500	112 000	6 350	11 400	3 700	5 500	RNA4913R	85	1	0.312
	90	34	1	84 000	165 000	8 600	16 800	3 700	5 500	RNA5913	85	1	0.462
	90	45	1	97 000	198 000	9 900	20 200	3 700	5 500	RNA6913R	85	1	0.520
73 ^{+0.049} _{+0.030}	90	25	0.6	54 000	100 000	5 500	10 200	3 700	5 500	NK73/25R	86	0.6	0.302
	90	35	0.6	76 500	156 000	7 800	16 000	3 700	5 500	NK73/35R	86	0.6	0.428
75 ^{+0.049} _{+0.030}	92	25	0.6	55 000	104 000	5 600	10 600	3 700	5 500	NK75/25R	88	0.6	0.315
	92	35	0.6	78 000	162 000	7 950	16 500	3 700	5 500	NK75/35R	88	0.6	0.492
80 ^{+0.049} _{+0.030}	95	25	1	57 000	119 000	5 800	12 200	3 300	5 000	NK80/25R	90	1	0.301
	95	35	1	79 500	184 000	8 150	18 700	3 300	5 000	NK80/35R	90	1	0.425
	100	30	1	85 500	156 000	8 750	15 900	3 300	5 000	RNA4914R	95	1	0.460
	100	40	1	103 000	187 000	10 500	19 100	3 300	5 000	RNA5914	95	1	0.706
	100	54	1	130 000	267 000	13 300	27 200	3 300	5 000	RNA6914R	95	1	0.857
85 ^{+0.058} _{+0.036}	105	25	1	70 500	123 000	7 200	12 600	3 100	4 700	NK85/25R	100	1	0.404
	105	30	1	87 000	162 000	8 900	16 500	3 100	4 700	RNA4915R	100	1	0.489
	105	35	1	100 000	193 000	10 200	19 700	3 100	4 700	NK85/35R	100	1	0.517
	105	40	1	109 000	205 000	11 100	20 900	3 100	4 700	RNA5915	100	1	0.745
	105	54	1	132 000	277 000	13 500	28 300	3 100	4 700	RNA6915R	100	1	0.935

Note 1) Allowable minimum chamfer dimension r .

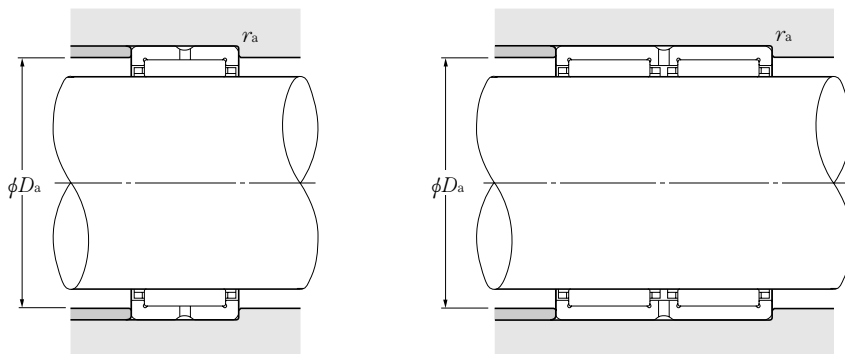

F_w 90~130mm

Boundary dimensions				Basic load ratings				Limiting speeds		Bearing numbers	Abutment and fillet dimensions		Mass kg (approx.)
mm				dynamic	static	dynamic	static	r/min			D_a	r_{as}	
F_w	D	B_e	$r_{s \min}^1$	C_r	C_{or}	C_r	C_{or}	grease	oil		max	max	
90 ^{+0.058} _{+0.036}	110	25	1	71 500	128 000	7 300	13 100	2 900	4 400	NK90/25R	105	1	0.426
	110	30	1	90 500	174 000	9 250	17 700	2 900	4 400	RNA4916R	105	1	0.516
	110	35	1	104 000	208 000	10 600	21 200	2 900	4 400	NK90/35R	105	1	0.604
	110	40	1	115 000	223 000	11 700	22 700	2 900	4 400	RNA5916	105	1	0.787
	110	54	1	137 000	298 000	14 000	30 500	2 900	4 400	RNA6916R	105	1	0.987
95 ^{+0.058} _{+0.036}	115	26	1	74 500	137 000	7 600	14 000	2 800	4 200	NK95/26R	110	1	0.364
	115	36	1	108 000	223 000	11 100	22 700	2 800	4 200	NK95/36R	110	1	0.652
100 ^{+0.058} _{+0.036}	120	26	1	73 500	137 000	7 500	14 000	2 700	4 000	NK100/26R	115	1	0.487
	120	35	1.1	112 000	237 000	11 500	24 200	2 700	4 000	RNA4917R	113.5	1	0.657
	120	36	1	107 000	223 000	11 000	22 800	2 700	4 000	NK100/36R	115	1	0.679
	120	46	1.1	137 000	290 000	14 000	29 600	2 700	4 000	RNA5917	113.5	1	1.00
	120	63	1.1	169 000	400 000	17 300	41 000	2 700	4 000	RNA6917R	113.5	1	1.20
105 ^{+0.058} _{+0.036}	125	26	1	76 500	147 000	7 800	14 900	2 500	3 800	NK105/26R	120	1	0.506
	125	35	1.1	116 000	252 000	11 900	25 700	2 500	3 800	RNA4918R	118.5	1	0.697
	125	36	1	111 000	238 000	11 400	24 300	2 500	3 800	NK105/36R	120	1	0.713
	125	46	1.1	143 000	310 000	14 600	32 000	2 500	3 800	RNA5918	118.5	1	1.04
	125	63	1.1	175 000	425 000	17 900	43 500	2 500	3 800	RNA6918R	118.5	1	1.33
110 ^{+0.058} _{+0.036}	130	30	1.1	97 500	204 000	9 950	20 800	2 400	3 600	NK110/30R	123.5	1	0.612
	130	35	1.1	118 000	260 000	12 000	26 500	2 400	3 600	RNA4919R	123.5	1	0.719
	130	40	1.1	129 000	292 000	13 100	29 700	2 400	3 600	NK110/40R	123.5	1	0.830
	130	46	1.1	149 000	335 000	15 200	34 000	2 400	3 600	RNA5919	123.5	1	1.13
	130	63	1.1	177 000	440 000	18 100	45 000	2 400	3 600	RNA6919R	123.5	1	1.46
115 ^{+0.058} _{+0.036}	140	40	1.1	127 000	260 000	12 900	26 500	2 300	3 500	RNA4920	133.5	1	1.15
	140	54	1.1	182 000	395 000	18 600	40 500	2 300	3 500	RNA5920	133.5	1	1.76
120 ^{+0.058} _{+0.036}	140	30	1	93 500	210 000	9 550	21 400	2 200	3 300	RNA4822	135	1	0.670
	140	40	1.1	113 000	268 000	11 500	27 300	2 200	3 300	NK120/40	133.5	1	0.910
125 ^{+0.068} _{+0.043}	150	40	1.1	131 000	279 000	13 300	28 400	2 100	3 200	RNA4922	143.5	1	1.24
	150	54	1.1	193 000	440 000	19 700	45 000	2 100	3 200	RNA5922	143.5	1	1.89
130 ^{+0.068} _{+0.043}	150	30	1	99 500	233 000	10 100	23 800	2 100	3 100	RNA4824	145	1	0.730

Note 1) Allowable minimum chamfer dimension r .

Without Inner Ring

Type RNA48

Type RNA49

Type RNA59

Type NK

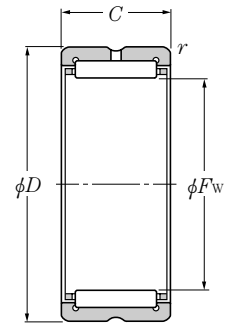

F_w 130~220mm

Boundary dimensions				Basic load ratings				Limiting speeds		Bearing numbers	Abutment dimensions		Mass kg (approx.)
mm				dynamic	static	dynamic	static	r/min			D_a	r_{as}	
F_w	D	C	r_s min ¹⁾	C_r	C_{or}	C_r	C_{or}	grease	oil		max	max	
130 ^{+0.068} / _{+0.043}	150	40	1.1	116 000	283 000	11 800	28 800	2 100	3 100	NK130/40	143.5	1	0.98
135 ^{+0.068} / _{+0.043}	165	45	1.1	180 000	380 000	18 300	38 500	2 000	3 000	RNA4924	158.5	1	1.86
	165	60	1.1	245 000	525 000	25 000	53 500	2 000	3 000	RNA5924	158.5	1	2.67
145 ^{+0.068} / _{+0.043}	165	35	1.1	118 000	305 000	12 100	31 000	1 900	2 800	RNA4826	158.5	1	0.95
	170	32	1.5	111 000	238 000	11 300	24 300	1 900	2 800	NK145/32	162.5	1.5	1.12
	170	42	1.5	153 000	360 000	15 600	36 500	1 900	2 800	NK145/42	162.5	1.5	1.49
150 ^{+0.068} / _{+0.043}	180	50	1.5	202 000	455 000	20 600	46 500	1 800	2 700	RNA4926	172	1.5	2.21
	180	67	1.5	294 000	685 000	30 000	70 000	1 800	2 700	RNA5926	172	1.5	3.21
155 ^{+0.068} / _{+0.043}	175	35	1.1	121 000	315 000	12 300	32 500	1 700	2 600	RNA4828	168.5	1	1.02
	180	32	1.5	114 000	252 000	11 600	25 700	1 700	2 600	NK155/32	172	1.5	1.20
	180	42	1.5	156 000	380 000	16 000	38 500	1 700	2 600	NK155/42	172	1.5	1.59
160 ^{+0.068} / _{+0.043}	190	50	1.5	209 000	485 000	21 300	49 500	1 700	2 500	RNA4928	182	1.5	2.35
	190	67	1.5	310 000	755 000	31 500	77 000	1 700	2 500	RNA5928	182	1.5	3.48
165 ^{+0.068} / _{+0.043}	190	32	1.5	117 000	265 000	11 900	27 000	1 600	2 400	NK165/32	182	1.5	1.42
	190	40	1.1	152 000	390 000	15 500	40 000	1 600	2 400	RNA4830	183.5	1	1.60
	190	42	1.5	160 000	400 000	16 300	40 500	1 600	2 400	NK165/42	182	1.5	1.66
170 ^{+0.068} / _{+0.043}	210	60	2	261 000	610 000	26 600	62 500	1 600	2 400	RNA4930	201	2	2.98
175 ^{+0.068} / _{+0.043}	200	40	1.1	160 000	425 000	16 300	43 500	1 500	2 300	RNA4832	193.5	1	1.70
180 ^{+0.068} / _{+0.043}	220	60	2	270 000	650 000	27 600	66 500	1 500	2 200	RNA4932	211	2	3.10
185 ^{+0.079} / _{+0.050}	215	45	1.1	185 000	495 000	18 800	50 500	1 500	2 200	RNA4834	208.5	1	2.54
190 ^{+0.079} / _{+0.050}	230	60	2	279 000	690 000	28 500	70 500	1 400	2 100	RNA4934	221	2	3.22
195 ^{+0.079} / _{+0.050}	225	45	1.1	195 000	540 000	19 800	55 000	1 400	2 100	RNA4836	218.5	1	2.68
205 ^{+0.079} / _{+0.050}	250	69	2	375 000	890 000	38 500	90 500	1 300	2 000	RNA4936	241	2	4.48
210 ^{+0.079} / _{+0.050}	240	50	1.5	227 000	680 000	23 200	69 000	1 300	1 900	RNA4838	232	1.5	3.21
215 ^{+0.079} / _{+0.050}	260	69	2	390 000	945 000	40 000	96 500	1 300	1 900	RNA4938	251	2	4.53
220 ^{+0.079} / _{+0.050}	250	50	1.5	231 000	705 000	23 600	71 500	1 200	1 800	RNA4840	242	1.5	3.35

Note 1) Allowable minimum chamfer dimension r .

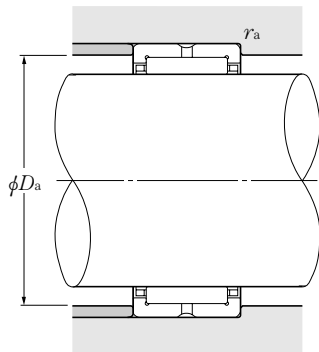

F_w 225~490mm

Boundary dimensions				Basic load ratings				Limiting speeds		Bearing numbers	Abutment and fillet dimensions		Mass kg (approx.)
mm				dynamic	static	dynamic	static	r/min			D_a	r_{as}	
F_w	D	B_e	$r_{s \min}^1$	C_r	C_{or}	C_r	C_{or}	grease	oil		max	max	
225 ^{+0.079} / _{+0.050}	280	80	2.1	505 000	1 180 000	51 500	120 000	1 200	1 800	RNA4940	269	2	7.20
240 ^{+0.079} / _{+0.050}	270	50	1.5	242 000	770 000	24 700	78 500	1 100	1 700	RNA4844	262	1.5	3.62
245 ^{+0.079} / _{+0.050}	300	80	2.1	525 000	1 270 000	53 500	129 000	1 100	1 600	RNA4944	289	2	7.81
265 ^{+0.088} / _{+0.056}	300	60	2	360 000	1 080 000	37 000	110 000	1 000	1 500	RNA4848	291	2	5.40
	320	80	2.1	540 000	1 350 000	55 000	138 000	1 000	1 500	RNA4948	309	2	8.40
285 ^{+0.088} / _{+0.056}	320	60	2	375 000	1 160 000	38 000	119 000	950	1 400	RNA4852	311	2	5.80
290 ^{+0.088} / _{+0.056}	360	100	2.1	805 000	1 900 000	82 000	193 000	950	1 400	RNA4952	349	2	15.90
305 ^{+0.088} / _{+0.056}	350	69	2	455 000	1 300 000	46 500	133 000	850	1 300	RNA4856	341	2	9.30
310 ^{+0.088} / _{+0.056}	380	100	2.1	835 000	2 030 000	85 000	207 000	850	1 300	RNA4956	369	2	16.70
330 ^{+0.098} / _{+0.062}	380	80	2.1	625 000	1 770 000	64 000	180 000	800	1 200	RNA4860	369	2	12.70
340 ^{+0.098} / _{+0.062}	420	118	3	1 080 000	2 640 000	110 000	269 000	800	1 200	RNA4960	407	2.5	24.00
350 ^{+0.098} / _{+0.062}	400	80	2.1	640 000	1 850 000	65 500	189 000	750	1 100	RNA4864	389	2	13.40
360 ^{+0.098} / _{+0.062}	440	118	3	1 120 000	2 820 000	114 000	288 000	750	1 100	RNA4964	427	2.5	25.20
370 ^{+0.098} / _{+0.062}	420	80	2.1	655 000	1 940 000	66 500	197 000	750	1 100	RNA4868	409	2	14.00
380 ^{+0.098} / _{+0.062}	460	118	3	1 160 000	3 000 000	118 000	305 000	750	1 100	RNA4968	447	2.5	26.50
390 ^{+0.098} / _{+0.062}	440	80	2.1	665 000	2 020 000	68 000	206 000	650	1 000	RNA4872	429	2	14.80
400 ^{+0.108} / _{+0.068}	480	118	3	1 200 000	3 200 000	122 000	325 000	650	1 000	RNA4972	467	2.5	28.20
415 ^{+0.108} / _{+0.068}	480	100	2.1	1 000 000	2 840 000	102 000	289 000	650	950	RNA4876	469	2	26.00
430 ^{+0.108} / _{+0.068}	520	140	4	1 400 000	3 750 000	143 000	385 000	650	950	RNA4976	504	3	38.60
450 ^{+0.108} / _{+0.068}	540	140	4	1 450 000	4 000 000	148 000	410 000	600	900	RNA4980	524	3	40.10
470 ^{+0.108} / _{+0.068}	560	140	4	1 500 000	4 250 000	153 000	430 000	550	850	RNA4984	544	3	51.60
490 ^{+0.108} / _{+0.068}	600	160	4	1 750 000	4 600 000	179 000	470 000	550	800	RNA4988	584	3	66.90

Note 1) Allowable minimum chamfer dimension r_s .

With inner ring

Type NA49
Type NA59
Type NA69
Type NK+IR

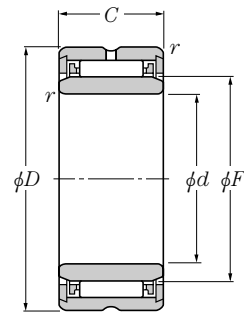

Type NA49 ($d \leq 9\text{mm}$)

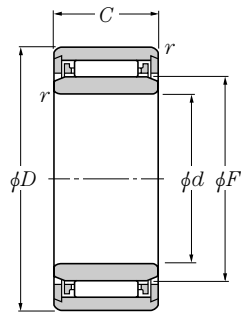

Type NK+IR ($d \leq 9\text{mm}$)

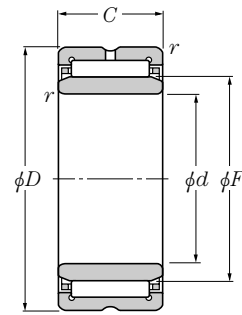

Type NA49·R ($d \geq 10\text{mm}$)
Type NA59
Type NA69·R
Type NK+IR ($d \geq 10\text{mm}$)

d 5~17mm

Boundary dimensions						Basic load ratings				Limiting speeds		Bearing numbers
mm						dynamic	static	dynamic	static	r/min		
d	D	C	$r_{s\min}^{1)}$	F	$s^{2)}$	C_r	C_{or}	C_r	C_{or}	grease	oil	
5	13	10	0.15	7	—	2 670	2 350	272	239	23 000	34 000	NA495T2
	15	12	0.3	8	1.5	4 000	4 100	410	420	21 000	32 000	NK8/12T2+IR5×8×12
	15	16	0.3	8	2	4 850	5 200	495	535	21 000	32 000	NK8/16T2+IR5×8×16
6	15	10	0.15	8	—	3 150	3 000	320	305	21 000	32 000	NA496
	16	12	0.3	9	1.5	4 550	5 000	465	510	20 000	30 000	NK9/12T2+IR6×9×12
	16	16	0.3	9	2	5 500	6 400	560	650	20 000	30 000	NK9/16T2+IR6×9×16
7	17	10	0.15	9	—	3 600	3 650	365	375	20 000	30 000	NA497
	17	12	0.3	10	1.5	4 550	5 100	460	520	19 000	28 000	NK10/12T2+IR7×10×12
	17	16	0.3	10	2	5 450	6 450	555	660	19 000	28 000	NK10/16+IR7×10×16
8	19	11	0.15	10	—	4 300	3 950	435	405	19 000	28 000	NA498
9	19	12	0.3	12	1.5	5 000	6 100	510	620	17 000	26 000	NK12/12+IR9×12×12
	19	16	0.3	12	2	6 000	7 700	615	785	17 000	26 000	NK12/16+IR9×12×16
	20	11	0.3	12	—	4 850	4 900	495	500	17 000	26 000	NA499
10	22	13	0.3	14	0.5	8 600	9 200	875	935	16 000	24 000	NA4900R
	22	16	0.3	14	0.5	10 300	11 500	1 050	1 170	16 000	24 000	NK14/16R+IR10×14×16
	22	20	0.3	14	0.5	13 000	15 600	1 330	1 590	16 000	24 000	NK14/20R+IR10×14×20
12	24	13	0.3	16	0.5	9 550	10 900	975	1 110	15 000	23 000	NA4901R
	24	16	0.3	16	0.5	12 200	14 900	1 240	1 520	15 000	23 000	NK16/16R+IR12×16×16
	24	20	0.3	16	0.5	14 600	18 800	1 490	1 920	15 000	23 000	NK16/20R+IR12×16×20
	24	22	0.3	16	1	15 400	20 000	1 570	2 040	15 000	23 000	NA6901R
15	27	16	0.3	19	0.5	13 300	17 400	1 350	1 780	14 000	21 000	NK19/16R+IR15×19×16
	27	20	0.3	19	0.5	16 000	22 200	1 630	2 260	14 000	21 000	NK19/20R+IR15×19×20
	28	13	0.3	20	0.5	10 300	12 800	1 050	1 310	13 000	20 000	NA4902R
	28	18	0.3	20	0.5	14 100	19 100	1 440	1 950	13 000	20 000	NA5902
	28	23	0.3	20	1	17 600	25 300	1 790	2 580	13 000	20 000	NA6902R
17	29	16	0.3	21	0.5	13 700	18 700	1 400	1 910	13 000	19 000	NK21/16R+IR17×21×16
	29	20	0.3	21	0.5	18 300	27 100	1 860	2 760	13 000	19 000	NK21/20R+IR17×21×20
	30	13	0.3	22	0.5	11 200	14 600	1 140	1 490	12 000	18 000	NA4903R
	30	18	0.3	22	0.5	15 200	21 700	1 550	2 210	12 000	18 000	NA5903

Note 1) Allowable minimum chamfer dimension r . 2) Allowable axial stroking value of inner ring against outer ring.
Remarks: Nominal code number of inner ring (IR) comprises the codes of IR bore diameter×outer diameter×width.

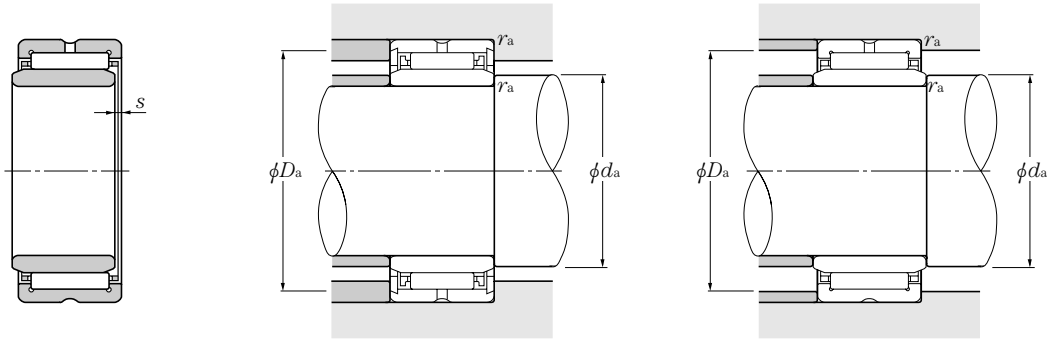

Abutment dimensions			Mass kg (approx.)
d_a min	mm D_a max	r_{as} max	
6.2	8.5	0.15	0.007
7	9.5	0.3	0.012
7	9.5	0.3	0.016
8	9.5	0.15	0.009
8	10.5	0.3	0.013
8	10.5	0.3	0.017
9	10.5	0.15	0.010
9	11.5	0.3	0.014
9	11.5	0.3	0.018
10	12	0.15	0.016
11	13.5	0.3	0.018
11	13.5	0.3	0.022
11	14	0.3	0.017
12	20	0.3	0.024
12	20	0.3	0.030
12	20	0.3	0.038
14	22	0.3	0.026
14	22	0.3	0.033
14	22	0.3	0.042
14	22	0.3	0.046
17	25	0.3	0.039
17	25	0.3	0.045
17	26	0.3	0.036
17	26	0.3	0.052
17	26	0.3	0.064
19	27	0.3	0.042
19	27	0.3	0.053
19	28	0.3	0.037
19	28	0.3	0.056

With inner ring

Type NA49
 Type NA59
 Type NA69
 Type NK+IR

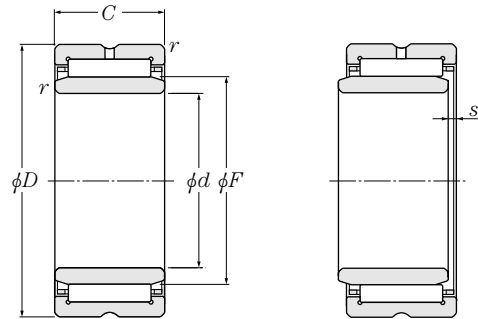

Type NA49 · R
 Type NA59
 Type NA69 · R ($d \leq 30\text{mm}$)
 Type NK+IR

d 17~32mm

Boundary dimensions						Basic load ratings				Limiting speeds		Bearing numbers
mm						dynamic	static	dynamic	static	r/min		
d	D	C	$r_{s \min}^{1)}$	F	$s^{2)}$	C_r	C_{or}	C_r	C_{or}	grease	oil	
17	30	23	0.3	22	1	18 200	27 200	1 850	2 770	12 000	18 000	NA6903R
	32	16	0.3	24	0.5	15 200	22 300	1 550	2 280	11 000	17 000	NK24/16R+IR20×24×16
20	32	20	0.3	24	0.5	18 600	28 800	1 890	2 930	11 000	17 000	NK24/20R+IR20×24×20
	37	17	0.3	25	0.8	21 300	25 500	2 170	2 600	11 000	16 000	NA4904R
	37	23	0.3	25	0.8	28 400	37 000	2 900	3 750	11 000	16 000	NA5904
	37	30	0.3	25	1	36 500	50 500	3 700	5 150	11 000	16 000	NA6904R
22	34	16	0.3	26	0.5	15 600	23 600	1 590	2 410	10 000	15 000	NK26/16R+IR22×26×16
	34	20	0.3	26	0.5	19 100	30 500	1 940	3 100	10 000	15 000	NK26/20R+IR22×26×20
	39	17	0.3	28	0.8	23 200	29 300	2 360	2 990	9 500	14 000	NA49/22R
	39	23	0.3	28	0.8	26 400	37 500	2 690	3 850	9 500	14 000	NA59/22
	39	30	0.3	28	0.5	40 000	58 500	4 050	6 000	9 500	14 000	NA69/22R
25	38	20	0.3	29	1	22 200	34 000	2 270	3 450	9 500	14 000	NK29/20R+IR25×29×20
	38	30	0.3	29	1.5	27 500	50 500	2 810	5 150	9 500	14 000	NK29/30R+IR25×29×30
	42	17	0.3	30	0.8	24 000	31 500	2 450	3 200	8 500	13 000	NA4905R
	42	23	0.3	30	0.8	30 500	43 000	3 150	4 350	8 500	13 000	NA5905
	42	30	0.3	30	1	41 500	63 000	4 200	6 400	8 500	13 000	NA6905R
28	42	20	0.3	32	1	23 500	37 500	2 400	3 850	8 500	13 000	NK32/20R+IR28×32×20
	42	30	0.3	32	1.5	34 000	60 500	3 450	6 150	8 500	13 000	NK32/30R+IR28×32×30
	45	17	0.3	32	0.8	24 800	33 500	2 530	3 400	8 500	13 000	NA49/28R
	45	23	0.3	32	0.8	32 000	45 500	3 250	4 650	8 500	13 000	NA59/28
	45	30	0.3	32	1	43 000	67 000	4 350	6 850	8 500	13 000	NA69/28R
30	45	20	0.3	35	0.5	24 800	41 500	2 520	4 250	7 500	11 000	NK35/20R+IR30×35×20
	45	30	0.3	35	1	36 000	66 500	3 650	6 800	7 500	11 000	NK35/30R+IR30×35×30
	47	17	0.3	35	0.8	25 500	35 500	2 600	3 600	7 500	11 000	NA4906R
	47	23	0.3	35	0.8	32 500	48 500	3 350	4 950	7 500	11 000	NA5906
	47	30	0.3	35	1	42 500	67 500	4 300	6 900	7 500	11 000	NA6906R
32	47	20	0.3	37	0.5	25 300	43 500	2 580	4 400	7 500	11 000	NK37/20R+IR32×37×20
	47	30	0.3	37	1	36 500	69 500	3 750	7 100	7 500	11 000	NK37/30R+IR32×37×30
	52	20	0.6	40	0.8	31 500	47 500	3 200	4 850	6 500	10 000	NA49/32R

Note 1) Allowable minimum chamfer dimension r . 2) Allowable axial stroking value of inner ring against outer ring.
 Remarks: Nominal code number of inner ring (IR) comprises the codes of IR bore diameter×outer diameter×width.

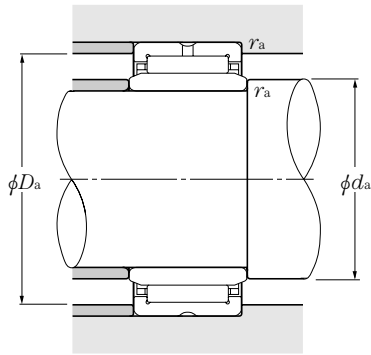

Abutment dimensions			Mass
d_a	mm		kg
min	D_a	r_{as}	(approx.)
	max	max	
19	28	0.3	0.069
22	30	0.3	0.049
22	30	0.3	0.061
22	35	0.3	0.074
22	35	0.3	0.115
22	35	0.3	0.141
24	32	0.3	0.046
24	32	0.3	0.064
24	37	0.3	0.080
24	37	0.3	0.134
24	37	0.3	0.154
27	36	0.3	0.079
27	36	0.3	0.123
27	40	0.3	0.088
27	40	0.3	0.139
27	40	0.3	0.162
30	40	0.3	0.096
30	40	0.3	0.146
30	43	0.3	0.098
30	43	0.3	0.142
30	43	0.3	0.179
32	43	0.3	0.112
32	43	0.3	0.171
32	45	0.3	0.101
32	45	0.3	0.152
32	45	0.3	0.185
34	45	0.3	0.117
34	45	0.3	0.170
36	48	0.6	0.157

With inner ring

Type NA49
Type NA59
Type NA69
Type NK+IR

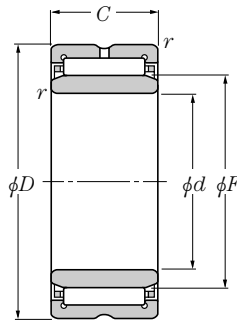

Type NA49 · R
Type NA59
Type NK · R + IR

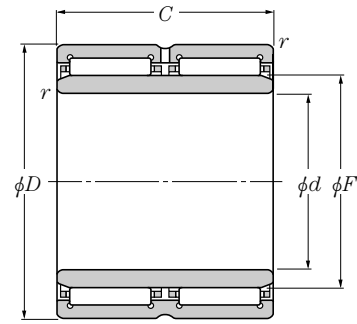

Type NA69 · R

d 32~55mm

Boundary dimensions						Basic load ratings				Limiting speeds		Bearing numbers
mm						dynamic	static	dynamic	static	r/min		
d	D	C	r _{s min} ¹⁾	F	s ²⁾	N		kgf		grease	oil	
						C _r	C _{0r}	C _r	C _{0r}			
32	52	27	0.6	40	0.8	38 000	61 000	3 850	6 250	6 500	10 000	NA59/32
	52	36	0.6	40	0.5	47 500	82 000	4 850	4 350	6 500	10 000	NA69/32R
35	50	20	0.3	40	0.5	26 400	47 000	2 700	4 800	6 500	10 000	NK40/20R + IR35 × 40 × 20
	50	30	0.3	40	1	38 500	76 000	3 900	7 750	6 500	10 000	NK40/30R + IR35 × 40 × 30
	55	20	0.6	42	0.8	32 000	50 000	3 300	5 100	6 500	9 500	NA4907R
	55	27	0.6	42	0.8	39 000	64 500	3 950	6 550	6 500	9 500	NA5907
	55	36	0.6	42	0.5	49 000	86 500	5 000	8 800	6 500	9 500	NA6907R
38	53	20	0.3	43	0.5	27 500	51 000	2 810	5 200	6 500	9 500	NK43/20R + IR38 × 43 × 20
	53	30	0.3	43	1	40 000	82 000	4 100	8 400	6 500	9 500	NK43/30R + IR38 × 43 × 30
40	55	20	0.3	45	0.5	28 000	52 500	2 860	5 400	6 000	9 000	NK45/20R + IR40 × 45 × 20
	55	30	0.3	45	1	41 000	85 500	4 150	8 700	6 000	9 000	NK45/30R + IR40 × 45 × 30
	62	22	0.6	48	1	43 500	66 500	4 450	6 800	5 500	8 500	NA4908R
	62	30	0.6	48	1	53 000	92 500	5 450	9 450	5 500	8 500	NA5908
	62	40	0.6	48	0.5	67 000	116 000	6 850	11 800	5 500	8 500	NA6908R
42	57	20	0.3	47	0.5	28 800	55 500	2 940	5 650	5 500	8 500	NK47/20R + IR42 × 47 × 20
	57	30	0.3	47	1	42 500	91 500	4 350	9 350	5 500	8 500	NK47/30R + IR42 × 47 × 30
45	62	25	0.6	50	1.5	38 500	74 500	3 950	7 550	5 500	8 000	NK50/25R + IR45 × 50 × 25
	62	35	0.6	50	2	51 000	106 000	5 200	10 800	5 500	8 000	NK50/35R + IR45 × 50 × 35
	68	22	0.6	52	1	46 000	73 000	4 700	7 450	5 000	7 500	NA4909R
	68	30	0.6	52	1	56 000	101 000	5 700	10 300	5 000	7 500	NA5909
	68	40	0.6	52	0.5	70 500	127 000	7 200	13 000	5 000	7 500	NA6909R
50	68	25	0.6	55	1.5	41 000	82 000	4 150	8 400	5 000	7 500	NK55/25R + IR50 × 55 × 25
	68	35	0.6	55	2	54 000	118 000	5 500	12 000	5 000	7 500	NK55/35R + IR50 × 55 × 35
	72	22	0.6	58	1	48 000	80 000	4 900	8 150	4 700	7 000	NA4910R
	72	30	0.6	58	1	58 000	110 000	5 950	11 200	4 700	7 000	NA5910
	72	40	0.6	58	0.5	74 000	139 000	7 500	14 200	4 700	7 000	NA6910R
55	72	25	0.6	60	1.5	41 000	85 000	4 200	8 700	4 300	6 500	NK60/25R + IR55 × 60 × 25
	72	35	0.6	60	2	57 000	130 000	5 800	13 200	4 300	6 500	NK60/35R + IR55 × 60 × 35
	80	25	1	63	1.5	58 500	99 500	6 000	10 100	4 300	6 500	NA4911R

Note 1) Allowable minimum chamfer dimension r . 2) Allowable axial stroking value of inner ring against outer ring.
Remarks: Nominal code number of inner ring (IR) comprises the codes of IR bore diameter × outer diameter × width.

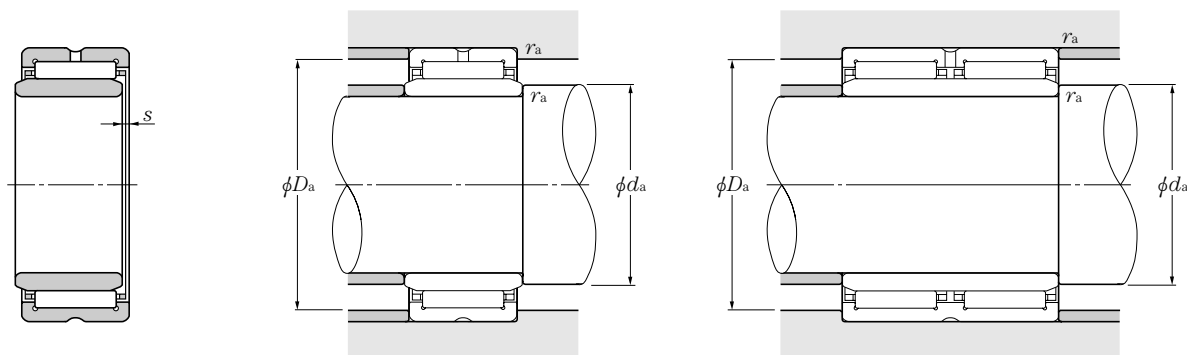

Abutment dimensions			Mass kg (approx.)
d_a min	mm D_a max	r_{as} max	
36	48	0.6	0.241
36	48	0.6	0.286
37	48	0.3	0.130
37	48	0.3	0.193
39	51	0.6	0.171
39	51	0.6	0.256
39	51	0.6	0.310
40	51	0.3	0.134
40	51	0.3	0.207
42	53	0.3	0.143
42	53	0.3	0.216
44	58	0.6	0.232
44	58	0.6	0.348
44	58	0.6	0.426
44	55	0.3	0.148
44	55	0.3	0.222
48	58	0.6	0.229
48	58	0.6	0.322
49	64	0.6	0.270
49	64	0.6	0.396
49	64	0.6	0.437
53	64	0.6	0.271
53	64	0.6	0.379
54	68	0.6	0.276
54	68	0.6	0.498
54	68	0.6	0.529
58	68	0.6	0.271
58	68	0.6	0.379
60	75	1	0.396

With inner ring

Type NA49
Type NA59
Type NA69
Type NK+IR

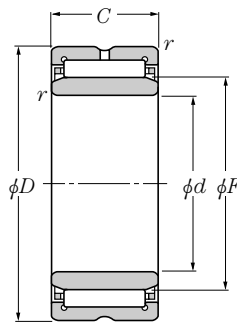

Type NA49 · · R
Type NA59
Type NK · · R + IR

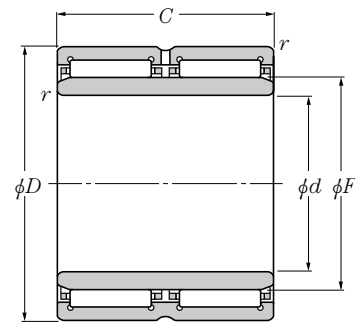

Type NA69 · · R

d 55~85mm

Boundary dimensions						Basic load ratings				Limiting speeds		Bearing numbers
mm						dynamic	static	dynamic	static	r/min		
d	D	C	r _{s min} ¹⁾	F	s ²⁾	N		kgf		grease	oil	
						C _r	C _{0r}	C _r	C _{0r}			
55	80	34	1	63	1.5	76 500	140 000	7 800	14 300	4 300	6 500	NA5911
	80	45	1	63	1.5	94 000	183 000	9 600	18 600	4 300	6 500	NA6911R
60	82	25	1	68	1	44 500	89 000	4 500	9 050	4 000	6 000	NK68/25R + IR60 × 68 × 25
	82	35	0.6	68	1	63 000	139 000	6 400	14 200	4 000	6 000	NK68/35R + IR60 × 68 × 35
	85	25	1	68	1.5	61 500	108 000	6 250	11 000	4 000	6 000	NA4912R
	85	34	1	68	1.5	80 500	153 000	8 200	15 600	4 000	6 000	NA5912
	85	45	1	68	1.5	95 500	191 000	9 750	19 400	4 000	6 000	NA6912R
65	90	25	0.6	73	1	54 000	100 000	5 500	10 200	3 700	5 500	NK73/25R + IR65 × 73 × 25
	90	25	1	72	1.5	62 500	112 000	6 350	11 400	3 700	5 500	NA4913R
	90	34	1	72	1.5	84 000	165 000	8 600	16 800	3 700	5 500	NA5913
	90	35	0.6	73	1	76 500	156 000	7 800	16 000	3 700	5 500	NK73/35R + IR65 × 73 × 35
	90	45	1	72	1.5	97 000	198 000	9 900	20 200	3 700	5 500	NA6913R
70	95	25	1	80	0.8	57 000	119 000	5 800	12 200	3 300	5 000	NK80/25R + IR70 × 80 × 25
	95	35	1	80	0.8	79 500	184 000	8 150	18 700	3 300	5 000	NK80/35R + IR70 × 80 × 35
	100	30	1	80	1.5	85 500	156 000	8 750	15 900	3 300	5 000	NA4914R
	100	40	1	80	1.5	103 000	187 000	10 500	19 100	3 300	5 000	NA5914
	100	54	1	80	1	130 000	267 000	13 300	27 200	3 300	5 000	NA6914R
75	105	25	1	85	1	70 500	123 000	7 200	12 600	3 100	4 700	NK85/25R + IR75 × 85 × 25
	105	30	1	85	1.5	87 000	162 000	8 900	16 500	3 100	4 700	NA4915R
	105	35	1	85	1	100 000	193 000	10 200	19 700	3 100	4 700	NK85/35R + IR75 × 85 × 35
	105	40	1	85	1.5	109 000	205 000	11 100	20 900	3 100	4 700	NA5915
	105	54	1	85	1	132 000	277 000	13 500	28 300	3 100	4 700	NA6915R
80	110	25	1	90	1	71 500	128 000	7 300	13 100	2 900	4 400	NK90/25R + IR80 × 90 × 25
	110	30	1	90	1.5	90 500	174 000	9 250	17 700	2 900	4 400	NA4916R
	110	35	1	90	1	104 000	208 000	10 600	21 200	2 900	4 400	NK90/35R + IR80 × 90 × 35
	110	40	1	90	1.5	115 000	223 000	11 700	22 700	2 900	4 400	NA5916
	110	54	1	90	1.5	137 000	298 000	14 000	30 500	2 900	4 400	NA6916R
85	115	26	1	95	1.5	74 500	137 000	7 600	14 000	2 800	4 200	NK95/26R + IR85 × 95 × 26
	115	36	1	95	1.5	108 000	223 000	11 100	22 700	2 800	4 200	NK95/36R + IR85 × 95 × 36

Note 1) Allowable minimum chamfer dimension r . 2) Allowable axial stroking value of inner ring against outer ring.
Remarks: Nominal code number of inner ring (IR) comprises the codes of IR bore diameter × outer diameter × width.

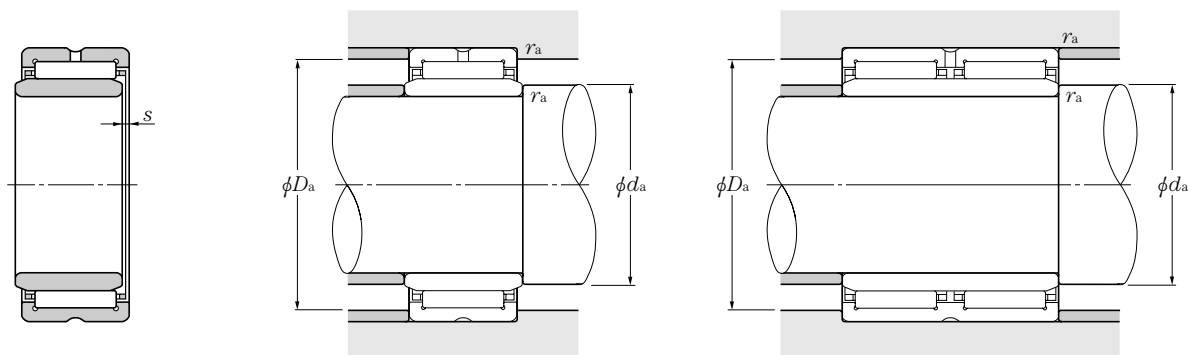

Abutment dimensions			Mass
d_a	mm		kg
min	max	max	(approx.)
60	75	1	0.559
60	75	1	0.726
65	77	0.6	0.393
64	78	0.6	0.551
65	80	1	0.427
65	80	1	0.614
65	80	1	0.758
69	86	0.6	0.466
70	85	1	0.454
70	85	1	0.655
69	86	0.6	0.660
70	85	1	0.779
75	90	1	0.525
75	90	1	0.738
75	95	1	0.727
75	95	1	1.06
75	95	1	1.34
80	100	1	0.642
80	100	1	0.776
80	100	1	0.853
80	100	1	1.13
80	100	1	1.45
85	105	1	0.680
85	105	1	0.820
85	105	1	0.959
85	105	1	1.15
85	105	1	1.53
90	110	1	0.644
90	110	1	1.05

With inner ring

Type NA48
Type NA49
Type NA59
Type NK+IR

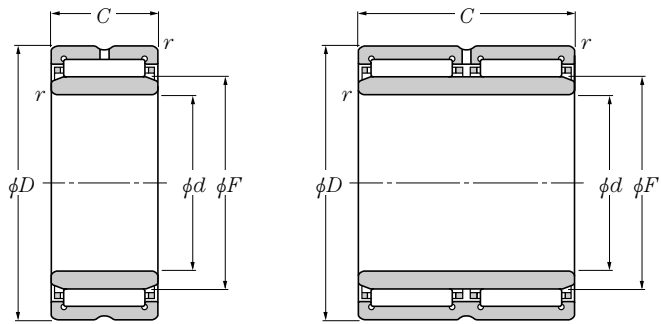

Type NA49·R, Type NA49
Type NA59
Type NK·R+IR, Type NK+IR

Type NA69·R

d 85~130mm

Boundary dimensions						Basic load ratings				Limiting speeds		Bearing numbers
mm						dynamic	static	dynamic	static	r/min		
d	D	C	r _{s min} ¹⁾	F	s ²⁾	N		kgf		grease	oil	
						C _r	C _{0r}	C _r	C _{0r}			
85	120	35	1.1	100	1	112 000	237 000	11 500	24 200	2 700	4 000	NA4917R
	120	46	1.1	100	1.5	137 000	290 000	14 000	29 600	2 700	4 000	NA5917
	120	63	1.1	100	1	169 000	400 000	17 300	41 000	2 700	4 000	NA6917R
90	120	26	1	100	1.5	73 500	137 000	7 500	14 000	2 700	4 000	NK100/26R+IR90×100×26
	120	36	1	100	1.5	107 000	223 000	11 000	22 800	2 700	4 000	NK100/36R+IR90×100×36
	125	35	1.1	105	1	116 000	252 000	11 900	25 700	2 500	3 800	NA4918R
	125	46	1.1	105	1	143 000	310 000	14 600	32 000	2 500	3 800	NA5918
	125	63	1.1	105	1	175 000	425 000	17 900	43 500	2 500	3 800	NA6918R
95	125	26	1	105	1.5	76 500	147 000	7 800	14 900	2 500	3 800	NK105/26R+IR95×105×26
	125	36	1	105	1.5	111 000	238 000	11 400	24 300	2 500	3 800	NK105/36R+IR95×105×36
	130	35	1.1	110	1	118 000	260 000	12 000	26 500	2 400	3 600	NA4919R
	130	46	1.1	110	1	149 000	335 000	15 200	34 000	2 400	3 600	NA5919
	130	63	1.1	110	1	177 000	440 000	18 100	45 000	2 400	3 600	NA6919R
100	130	30	1.1	110	1.5	97 500	204 000	9 950	20 800	2 400	3 600	NK110/30R+IR100×110×30
	130	40	1.1	110	2	129 000	292 000	13 100	29 700	2 400	3 600	NK110/40R+IR100×110×40
	140	40	1.1	115	2	127 000	260 000	12 900	26 500	2 300	3 500	NA4920
	140	54	1.1	115	2	182 000	395 000	18 600	40 500	2 300	3 500	NA5920
110	140	30	1	120	0.8	93 500	210 000	9 550	21 400	2 200	3 300	NA4822
	140	40	1.1	120	—	113 000	268 000	11 500	27 300	2 200	3 300	NK120/40+IR110×120×40
	150	40	1.1	125	2	131 000	279 000	13 300	28 400	2 100	3 200	NA4922
	150	54	1.1	125	2	193 000	440 000	19 700	45 000	2 100	3 200	NA5922
120	150	30	1	130	0.8	99 500	233 000	10 100	23 800	2 100	3 100	NA4824
	150	40	1.1	130	—	116 000	283 000	11 800	28 800	2 100	3 100	NK130/40+IR120×130×40
	165	45	1.1	135	2	180 000	380 000	18 300	38 500	2 000	3 000	NA4924
	165	60	1.1	135	2	245 000	525 000	25 000	53 500	2 000	3 000	NA5924
130	165	35	1.1	145	1	118 000	305 000	12 100	31 000	1 900	2 800	NA4826
	170	32	1.5	145	—	111 000	238 000	11 300	24 300	1 900	2 800	NK145/32+IR130×145×32
	170	42	1.5	145	—	153 000	360 000	15 600	36 500	1 900	2 800	NK145/42+IR130×145×42
	180	50	1.5	150	1.5	202 000	455 000	20 600	46 500	1 800	2 700	NA4926

Note 1) Allowable minimum chamfer dimension r . 2) Allowable axial stroking value of inner ring against outer ring.
Remarks: Nominal code number of inner ring (IR) comprises the codes of IR bore diameter×outer diameter×width.

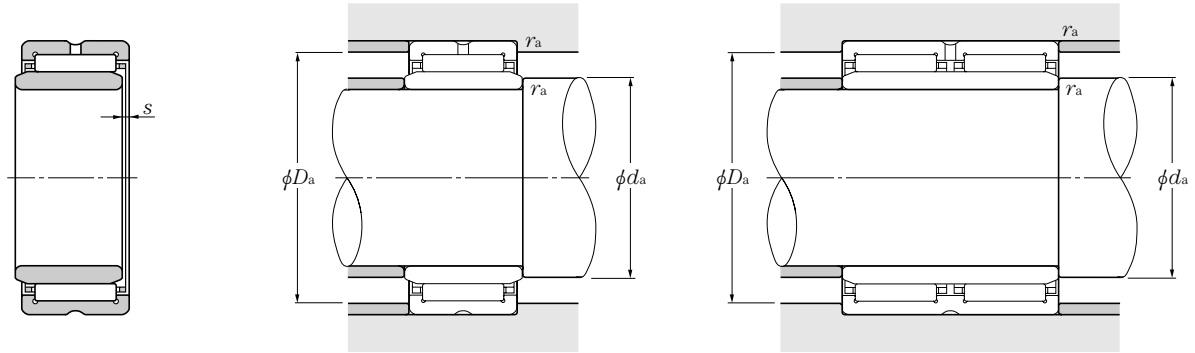

Abutment dimensions			Mass kg (approx.)
d_a min	mm D_a max	r_{as} max	
91.5	113.5	1	1.24
91.5	113.5	1	1.76
91.5	113.5	1	2.25
95	115	1	0.781
95	115	1	1.09
96.5	118.5	1	1.31
96.5	118.5	1	1.84
96.5	118.5	1	2.44
100	120	1	0.819
100	120	1	1.15
101.5	123.5	1	1.36
101.5	123.5	1	1.98
101.5	123.5	1	2.63
106.5	123.5	1	0.990
106.5	123.5	1	1.34
106.5	133.5	1	1.93
106.5	133.5	1	2.85
115	135	1	1.11
116.5	133.5	1	1.49
116.5	143.5	1	2.08
116.5	143.5	1	2.98
125	145	1	1.17
126.5	143.5	1	1.57
126.5	158.5	1	2.84
126.5	158.5	1	3.92
136.5	158.5	1	1.60
138	162.5	1.5	1.90
138	162.5	1.5	2.54
138	172	1.5	3.90

With inner ring

Type NA48

Type NA49

Type NA59

Type NK+IR

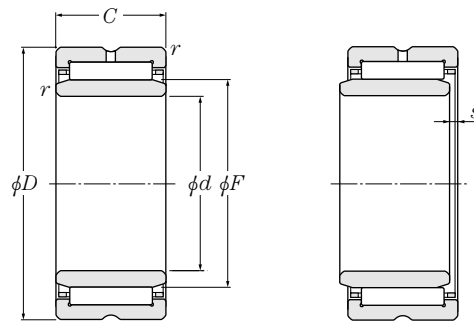

d 130~280mm

Boundary dimensions						Basic load ratings				Limiting speeds		Bearing numbers
mm						dynamic	static	dynamic	static	r/min		
d	D	C	r _{s min} ¹⁾	F	s ²⁾	N		kgf		grease	oil	
						C _r	C _{0r}	C _r	C _{0r}			
130	180	67	1.5	150	1.5	294 000	685 000	30 000	70 000	1 800	2 700	NA5926
	175	35	1.1	155	1	121 000	315 000	12 300	32 500	1 700	2 600	NA4828
140	180	32	1.5	155	—	114 000	252 000	11 600	25 700	1 700	2 600	NK155/32 + IR140×155×32
	180	42	1.5	155	—	156 000	380 000	16 000	38 500	1 700	2 600	NK155/42 + IR140×155×42
	190	50	1.5	160	1.5	209 000	485 000	21 300	49 500	1 700	2 500	NA4928
	190	67	1.5	160	1.5	310 000	755 000	31 500	77 000	1 700	2 500	NA5928
150	190	32	1.5	165	—	117 000	265 000	11 900	27 000	1 600	2 400	NK165/32 + IR150×165×32
	190	40	1.1	165	1.5	152 000	390 000	15 500	40 000	1 600	2 400	NA4830
	190	42	1.5	165	—	160 000	400 000	16 300	40 500	1 600	2 400	NK165/42 + IR150×165×42
	210	60	2	170	1.5	261 000	610 000	26 600	62 500	1 600	2 400	NA4930
160	200	40	1.1	175	1.5	160 000	425 000	16 300	43 500	1 500	2 300	NA4832
	220	60	2	180	1.5	270 000	650 000	27 600	66 500	1 500	2 200	NA4932
170	215	45	1.1	185	1.5	185 000	495 000	18 800	50 500	1 500	2 200	NA4834
	230	60	2	190	1.5	279 000	690 000	28 500	70 500	1 400	2 100	NA4934
180	225	45	1.1	195	1.5	195 000	540 000	19 800	55 000	1 400	2 100	NA4836
	250	69	2	205	1.5	375 000	890 000	38 500	90 500	1 300	2 000	NA4936
190	240	50	1.5	210	1.5	227 000	680 000	23 200	69 000	1 300	1 900	NA4838
	260	69	2	215	1.5	390 000	945 000	40 000	96 500	1 300	1 900	NA4938
200	250	50	1.5	220	1.5	231 000	705 000	23 600	71 500	1 200	1 800	NA4840
	280	80	2.1	225	1.5	505 000	1 180 000	51 500	120 000	1 200	1 800	NA4940
220	270	50	1.5	240	1.5	244 000	780 000	24 900	79 500	1 100	1 700	NA4844
	300	80	2.1	245	1.5	525 000	1 270 000	53 500	129 000	1 100	1 600	NA4944
240	300	60	2	265	2	360 000	1 080 000	37 000	110 000	1 000	1 500	NA4848
	320	80	2.1	265	2	540 000	1 350 000	55 000	138 000	1 000	1 500	NA4948
260	320	60	2	285	2	375 000	1 160 000	38 000	119 000	950	1 400	NA4852
	360	100	2.1	290	2	805 000	1 900 000	82 000	193 000	950	1 400	NA4952
280	350	69	2	305	2.5	455 000	1 300 000	46 500	133 000	850	1 300	NA4856
	380	100	2.1	310	2.5	835 000	2 030 000	85 000	207 000	850	1 300	NA4956

Note 1) Allowable minimum chamfer dimension r . 2) Allowable axial stroking value of inner ring against outer ring.
Remarks: Nominal code number of inner ring (IR) comprises the codes of IR bore diameter×outer diameter×width.

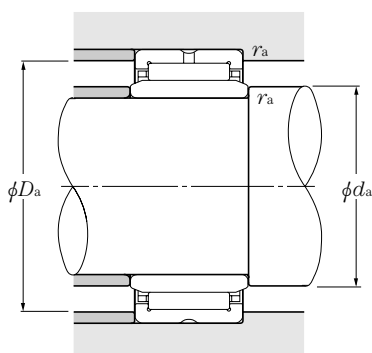

Abutment dimensions			Mass
d_a	mm D_a		kg
min	max	r_{as} max	(approx.)
138	172	1.5	5.60
146.5	168.5	1	1.82
148	172	1.5	2.04
148	172	1.5	2.69
148	182	1.5	4.05
148	182	1.5	6.18
158	182	1.5	2.32
156.5	183.5	1	2.72
158	182	1.5	2.84
159	201	2	5.33
166.5	193.5	1	2.90
169	211	2	5.60
176.5	208.5	1	3.99
179	221	2	5.87
186.5	218.5	1	4.19
189	241	2	8.58
198	232	1.5	5.62
199	251	2	8.68
208	242	1.5	5.84
211	269	2	12.2
228	262	1.5	6.37
231	289	2	13.5
249	291	2	10.0
251	309	2	14.7
269	311	2	10.8
271	349	2	25.9
289	341	2	15.5
291	369	2	27.5

With inner ring

Type NA48

Type NA49

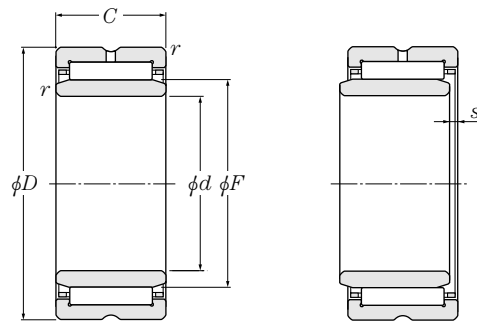

d 300~440mm

Boundary dimensions						Basic load ratings				Limiting speeds		Bearing numbers
mm						dynamic	static	dynamic	static	r/min		
d	D	C	$r_{s\min}^{1)}$	F	$s^{2)}$	N		kgf		grease	oil	
						C_r	C_{or}	C_r	C_{or}			
300	380	80	2.1	330	2	625 000	1 770 000	64 000	180 000	800	1 200	NA4860
	420	118	3	340	2	1 080 000	2 640 000	110 000	269 000	800	1 200	NA4960
320	400	80	2.1	350	2	640 000	1 850 000	65 500	189 000	750	1 100	NA4864
	440	118	3	360	2	1 120 000	2 820 000	114 000	288 000	750	1 100	NA4964
340	420	80	2.1	370	2	655 000	1 940 000	66 500	197 000	750	1 100	NA4868
	460	118	3	380	2	1 160 000	3 000 000	118 000	305 000	750	1 100	NA4968
360	440	80	2.1	390	2	665 000	2 020 000	68 000	206 000	650	1 000	NA4872
	480	118	3	400	2	1 200 000	3 200 000	122 000	325 000	650	1 000	NA4972
380	480	100	2.1	415	2	1 000 000	2 840 000	102 000	289 000	650	950	NA4876
	520	140	4	430	2	1 400 000	3 750 000	143 000	385 000	650	950	NA4976
400	540	140	4	450	2.5	1 450 000	4 000 000	148 000	410 000	600	900	NA4980
420	560	140	4	470	2.5	1 500 000	4 250 000	153 000	430 000	550	850	NA4984
440	600	160	4	490	2.5	1 750 000	4 600 000	179 000	470 000	550	800	NA4988

Note 1) Allowable minimum chamfer dimension r . 2) Allowable axial stroking value of inner ring against outer ring.

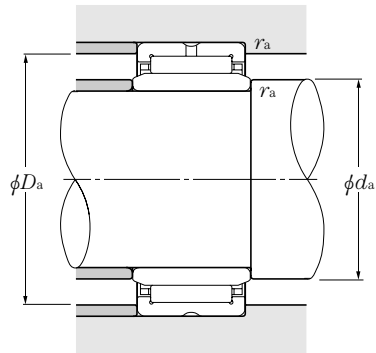

Abutment dimensions			Mass
d_a	mm		kg
min	max	r_{as} max	(approx.)
311	369	2	22.0
313	407	2.5	42.5
331	389	2	23.2
333	427	2.5	45.2
351	409	2	24.1
353	447	2.5	47.3
371	429	2	25.7
373	467	2.5	49.0
391	469	2	44.5
396	504	3	73.6
416	524	3	76.6
436	544	3	89.8
456	584	3	123

Inch series
Without inner ring

Type MR

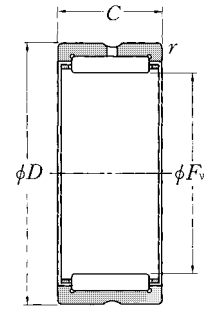

F_w 15.875~63.500mm

F_w	Boundary dimensions				dynamic N	Basic load ratings				Limiting speeds	
	mm ($\frac{1}{25.4}$ mm)					static	dynamic	static	kgf	grease	oil
		D	C	$r_{s \min}^1$	C_r	C_{or}	C_r	C_{or}	r/min (approx.)		
15.875 ($\frac{5}{8}$)	+0.027 +0.016	28.575($1\frac{1}{8}$)	19.05($\frac{3}{4}$)	0.6	16 700	16 700	1 700	1 700	17 000	25 000	
		28.575($1\frac{1}{8}$)	25.40(1)	0.6	21 500	23 000	2 190	2 350	17 000	25 000	
19.050 ($\frac{3}{4}$)	+0.033 +0.020	31.750($1\frac{1}{4}$)	19.05($\frac{3}{4}$)	1	19 500	21 100	1 980	2 150	14 000	21 000	
		31.750($1\frac{1}{4}$)	25.40(1)	1	25 000	29 100	2 550	2 970	14 000	21 000	
22.225 ($\frac{7}{8}$)	+0.033 +0.020	34.925($1\frac{3}{8}$)	19.05($\frac{3}{4}$)	1	21 900	25 600	2 240	2 610	12 000	18 000	
		34.925($1\frac{3}{8}$)	25.40(1)	1	28 200	35 500	2 870	3 600	12 000	18 000	
25.400 (1)	+0.033 +0.020	38.100($1\frac{1}{2}$)	19.05($\frac{3}{4}$)	1	23 000	28 100	2 340	2 870	11 000	16 000	
		38.100($1\frac{1}{2}$)	25.40(1)	1	29 500	38 500	3 000	3 950	11 000	16 000	
28.575 ($1\frac{1}{8}$)	+0.033 +0.020	41.275($1\frac{5}{8}$)	25.40(1)	1	32 500	45 000	3 300	4 600	9 500	14 000	
		41.275($1\frac{5}{8}$)	31.75($1\frac{1}{4}$)	1	40 500	60 000	4 100	6 100	9 500	14 000	
31.750 ($1\frac{1}{4}$)	+0.041 +0.025	44.450($1\frac{3}{4}$)	25.40(1)	1	35 000	51 000	3 550	5 200	8 500	13 000	
		44.450($1\frac{3}{4}$)	31.75($1\frac{1}{4}$)	1	43 500	68 000	4 450	6 950	8 500	13 000	
34.925 ($1\frac{3}{8}$)	+0.041 +0.025	47.625($1\frac{7}{8}$)	25.40(1)	1	37 000	57 500	3 800	5 850	7 500	11 000	
		47.625($1\frac{7}{8}$)	31.75($1\frac{1}{4}$)	1	46 500	76 500	4 750	7 800	7 500	11 000	
38.100 ($1\frac{1}{2}$)	+0.041 +0.025	52.388($2\frac{1}{6}$)	25.40(1)	1.5	41 000	61 000	4 150	6 250	7 500	11 000	
		52.388($2\frac{1}{6}$)	31.75($1\frac{1}{4}$)	1.5	51 000	81 500	5 200	8 300	7 500	11 000	
41.275 ($1\frac{5}{8}$)	+0.041 +0.025	55.562($2\frac{3}{6}$)	25.40(1)	1.5	43 500	68 000	4 450	6 950	6 500	9 500	
		55.562($2\frac{3}{6}$)	31.75($1\frac{1}{4}$)	1.5	54 500	90 500	5 550	9 250	6 500	9 500	
44.450 ($1\frac{3}{4}$)	+0.041 +0.025	58.738($2\frac{5}{6}$)	25.40(1)	1.5	44 500	72 000	4 550	7 350	6 000	9 000	
		58.738($2\frac{5}{6}$)	31.75($1\frac{1}{4}$)	1.5	55 500	95 500	5 700	9 750	6 000	9 000	
47.625 ($1\frac{7}{8}$)	+0.041 +0.025	61.912($2\frac{7}{6}$)	31.75($1\frac{1}{4}$)	1.5	59 000	105 000	6 000	10 700	5 500	8 500	
50.800 (2)	+0.049 +0.030	65.088($2\frac{9}{6}$)	25.40(1)	1.5	49 500	86 000	5 050	8 800	5 500	8 000	
		65.088($2\frac{9}{6}$)	31.75($1\frac{1}{4}$)	1.5	62 000	114 000	6 300	11 700	5 500	8 000	
57.150 ($2\frac{1}{4}$)	+0.049 +0.030	76.200(3)	38.10($1\frac{1}{2}$)	1.5	83 500	142 000	8 500	14 500	4 700	7 000	
		76.200(3)	44.45($1\frac{3}{4}$)	1.5	97 000	173 000	9 850	17 600	4 700	7 000	
63.500 ($2\frac{1}{2}$)	+0.049 +0.030	82.550($3\frac{1}{4}$)	38.10($1\frac{1}{2}$)	2	88 000	158 000	8 950	16 100	4 300	6 500	

Note 1) Allowable minimum chamfer dimension r .

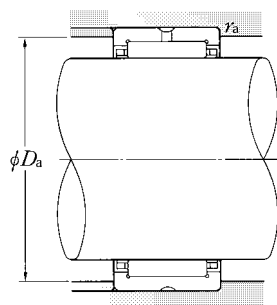

Bearing numbers	Abutment dimensions mm		Mass kg (approx.)
	D_a max	r_{as} max	
MR101812	24.5	0.6	0.050
MR101816	24.5	0.6	0.068
MR122012	26.5	1	0.055
MR122016	26.5	1	0.073
MR142212	30	1	0.059
MR142216	30	1	0.082
MR162412	33	1	0.068
MR162416	33	1	0.091
MR182616	36.5	1	0.100
MR182620	36.5	1	0.127
MR202816	39.5	1	0.109
MR202820	39.5	1	0.136
MR223016	42.5	1	0.118
MR223020	42.5	1	0.150
MR243316	46	1.5	0.143
MR243320	46	1.5	0.180
MR263516	49	1.5	0.153
MR263520	49	1.5	0.191
MR283716	52	1.5	0.163
MR283720	52	1.5	0.204
MR303920	55.5	1.5	0.216
MR324116	58.5	1.5	0.183
MR324120	58.5	1.5	0.227
MR364824	69.5	1.5	0.422
MR364828	69.5	1.5	0.493
MR405224	74.5	2	0.472

Inch series

Without inner ring

Type MR

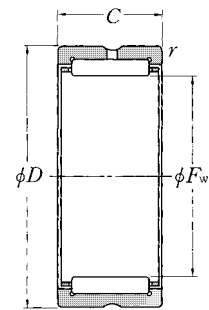

F_w 63.500~184.150mm

Boundary dimensions				Basic load ratings				Limiting speeds		
F_w	mm			dynamic	static	dynamic	static	r/min		
	D	C	$r_{s \min}^1$	C_r	C_{or}	C_r	C_{or}	grease	oil	
63.500(2 1/2)	+0.049 +0.030	82.550(3 1/4)	44.45(1 3/4)	2	102 000	191 000	10 400	19 500	4 300	6 500
	69.850(2 3/4)	+0.049 +0.030	88.900(3 1/2)	25.40(1)	2	66 000	112 000	6 700	11 400	3 700
+0.049 +0.030		88.900(3 1/2)	38.10(1 1/2)	2	92 000	173 000	9 400	17 600	3 700	5 500
+0.049 +0.030		88.900(3 1/2)	44.45(1 3/4)	2	107 000	209 000	10 900	21 300	3 700	5 500
76.200(3)	+0.049 +0.030	95.250(3 3/4)	38.10(1 1/2)	2	96 000	188 000	9 800	19 100	3 300	5 000
	+0.049 +0.030	95.250(3 3/4)	44.45(1 3/4)	2	112 000	227 000	11 400	23 200	3 300	5 000
82.550(3 1/4)	+0.058 +0.036	107.950(4 1/4)	44.45(1 3/4)	2	134 000	240 000	13 600	24 500	3 300	5 000
	+0.058 +0.036	107.950(4 1/4)	50.80(2)	2	146 000	268 000	14 900	27 400	3 300	5 000
88.900(3 1/2)	+0.058 +0.036	114.300(4 1/2)	44.45(1 3/4)	2	141 000	264 000	14 400	26 900	3 000	4 500
	+0.058 +0.036	114.300(4 1/2)	50.80(2)	2	154 000	295 000	15 700	30 000	3 000	4 500
95.250(3 3/4)	+0.058 +0.036	120.650(4 3/4)	50.80(2)	2.5	162 000	320 000	16 500	32 500	2 800	4 200
101.600(4)	+0.058 +0.036	127.000(5)	50.80(2)	2.5	169 000	345 000	17 200	35 500	2 600	3 900
107.950(4 1/4)	+0.058 +0.036	133.350(5 1/4)	50.80(2)	2.5	172 000	360 000	17 500	37 000	2 500	3 700
114.300(4 1/2)	+0.058 +0.036	152.400(6)	57.15(2 1/4)	2.5	238 000	435 000	24 300	44 500	2 300	3 500
	+0.058 +0.036	152.400(6)	63.50(2 1/2)	2.5	260 000	485 000	26 500	49 500	2 300	3 500
127.000(5)	+0.068 +0.043	165.100(6 1/2)	50.80(2)	2.5	227 000	425 000	23 200	43 000	2 100	3 100
	+0.068 +0.043	165.100(6 1/2)	57.15(2 1/4)	2.5	250 000	480 000	25 500	49 000	2 100	3 100
	+0.068 +0.043	165.100(6 1/2)	63.50(2 1/2)	2.5	273 000	535 000	27 800	54 500	2 100	3 100
139.700(5 1/2)	+0.068 +0.043	177.800(7)	63.50(2 1/2)	2.5	285 000	585 000	29 100	59 500	1 900	2 900
	+0.068 +0.043	177.800(7)	76.20(3)	2.5	345 000	740 000	35 000	75 500	1 900	2 900
146.050(5 3/4)	+0.068 +0.043	184.150(7 1/4)	76.20(3)	3	360 000	775 000	36 500	79 000	1 800	2 700
152.400(6)	+0.068 +0.043	190.500(7 1/2)	63.50(2 1/2)	3	310 000	630 000	31 500	64 000	1 700	2 600
	+0.068 +0.043	190.500(7 1/2)	76.20(3)	3	375 000	800 000	38 000	81 500	1 700	2 600
165.100(6 1/2)	+0.068 +0.043	203.200(8)	63.50(2 1/2)	3	325 000	680 000	33 000	69 500	1 600	2 400
	+0.068 +0.043	203.200(8)	76.20(3)	3	390 000	870 000	39 500	88 500	1 600	2 400
184.150(7 1/4)	+0.079 +0.050	231.775(9 1/8)	76.20(3)	3	435 000	915 000	44 500	93 000	1 500	2 200

Note 1) Allowable minimum chamfer dimension r .

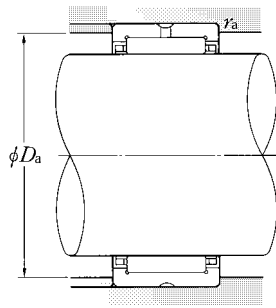

Bearing numbers	Abutment dimensions mm		Mass kg (approx.)
	D_a max	r_{as} max	
MR405228	74.5	2	0.533
MR445616	81	2	0.343
MR445624	81	2	0.504
MR445628	81	2	0.580
MR486024	87	2	0.558
MR486028	87	2	0.651
MR526828	100	2	1.02
MR526832	100	2	1.17
MR567228	106.5	2	1.08
MR567232	106.5	2	1.27
MR607632	111.5	2.5	1.28
MR648032	118	2.5	1.29
MR688432	124.5	2.5	1.36
MR729636	143.5	2.5	2.62
MR729640	143.5	2.5	2.91
MR8010432	156	2.5	2.53
MR8010436	156	2.5	2.87
MR8010440	156	2.5	3.19
MR8811240	169	2.5	3.46
MR8811248	169	2.5	4.16
MR9211648	172	3	4.30
MR9612040	177.5	3	3.74
MR9612048	177.5	3	4.49
MR10412840	190	3	4.02
MR10412848	190	3	4.82
MR11614648	219	3	7.36

Inch series
Without inner ring

Type MR

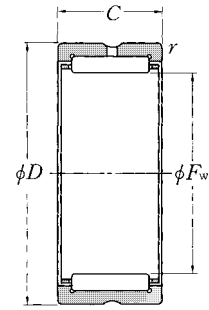

F_w 196.850~234.950mm

Boundary dimensions					Basic load ratings				Limiting speeds	
mm					dynamic	static	dynamic	static	r/min	
F_w	D	C	$r_{s \min}^{1)}$		N		kgf		grease	oil
					C_r	C_{or}	C_r	C_{or}	(approx.)	
196.850(7 $\frac{3}{4}$)	$\begin{matrix} +0.079 \\ +0.050 \end{matrix}$ 244.475(9 $\frac{5}{8}$)	76.20(3)	3		455 000	990 000	46 500	101 000	1 300	2 000
209.550(8 $\frac{1}{4}$)	$\begin{matrix} +0.079 \\ +0.050 \end{matrix}$ 257.175(10 $\frac{1}{8}$)	76.20(3)	3		475 000	1 060 000	48 500	109 000	1 300	1 900
222.250(8 $\frac{3}{4}$)	$\begin{matrix} +0.079 \\ +0.050 \end{matrix}$ 269.875(10 $\frac{5}{8}$)	76.20(3)	4		495 000	1 140 000	50 500	116 000	1 200	1 800
234.950(9 $\frac{1}{4}$)	$\begin{matrix} +0.079 \\ +0.050 \end{matrix}$ 282.575(11 $\frac{1}{8}$)	76.20(3)	4		510 000	1 210 000	52 000	124 000	1 100	1 700

Note 1) Allowable minimum chamfer dimension r .

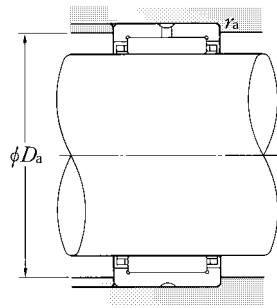

Bearing numbers	Abutment dimensions mm		Mass kg (approx.)
	D_a max	r_{as} max	
MR12415448	231.5	3	7.80
MR13216248	244	3	8.36
MR14017048	254	4	8.81
MR14817848	266.5	4	9.27

Inch series With inner ring

Type MR + MI

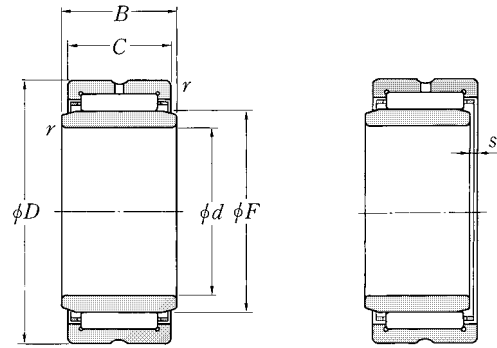

d 9.525~34.925mm

d	Boundary dimensions						Basic load ratings			
	D	B	C	r 's min ¹⁾	F	s ²⁾	dynamic N	static N	dynamic kgf	static kgf
9.525($\frac{3}{8}$)	28.575($1\frac{1}{8}$)	19.30	19.05($\frac{3}{4}$)	0.6	15.875	2	16 700	16 700	1 700	1 700
	28.575($1\frac{1}{8}$)	25.65	25.40(1)	0.6	15.875	3	21 500	23 000	2 190	2 350
12.700($\frac{1}{2}$)	31.750($1\frac{1}{4}$)	19.30	19.05($\frac{3}{4}$)	1	19.050	4	19 500	21 100	1 980	2 150
	31.750($1\frac{1}{4}$)	25.65	25.40(1)	1	19.050	2	25 000	29 100	2 550	2 970
15.875($\frac{5}{8}$)	34.925($1\frac{3}{8}$)	19.30	19.05($\frac{3}{4}$)	1	22.225	1	21 900	25 600	2 240	2 610
	34.925($1\frac{3}{8}$)	25.65	25.40(1)	1	22.225	2	28 200	35 500	2 870	3 600
17.462($1\frac{1}{16}$)	34.925($1\frac{3}{8}$)	19.30	19.05($\frac{3}{4}$)	1	22.225	1.5	21 900	25 600	2 240	2 610
	38.100($1\frac{1}{2}$)	19.30	19.05($\frac{3}{4}$)	1	25.400	1	23 000	28 100	2 340	2 870
19.050($\frac{3}{4}$)	38.100($1\frac{1}{2}$)	25.65	25.40(1)	1	25.400	1.5	29 500	38 500	3 000	3 950
	38.100($1\frac{1}{2}$)	25.65	25.40(1)	1	25.400	2	29 500	38 500	3 000	3 950
20.638($1\frac{3}{16}$)	41.275($1\frac{5}{8}$)	25.65	25.40(1)	1	28.575	1.5	32 500	45 000	3 300	4 600
	41.275($1\frac{5}{8}$)	32.00	31.75($1\frac{1}{4}$)	1	28.575	2	40 500	60 000	4 100	6 100
22.225($\frac{7}{8}$)	41.275($1\frac{5}{8}$)	25.65	25.40(1)	1	28.575	2	32 500	45 000	3 300	4 600
	41.275($1\frac{5}{8}$)	32.00	31.75($1\frac{1}{4}$)	1	28.575	2	40 500	60 000	4 100	6 100
23.812($1\frac{15}{16}$)	44.450($1\frac{3}{4}$)	25.65	25.40(1)	1	31.750	1.5	35 000	51 000	3 550	5 200
	44.450($1\frac{3}{4}$)	32.00	31.75($1\frac{1}{4}$)	1	31.750	2	43 500	68 000	4 450	6 950
25.400(1)	47.625($1\frac{7}{8}$)	25.65	25.40(1)	1	34.925	3	37 000	57 500	3 800	5 850
	47.625($1\frac{7}{8}$)	32.00	31.75($1\frac{1}{4}$)	1	34.925	2	46 500	76 500	4 750	7 800
28.575($1\frac{1}{8}$)	52.388($2\frac{1}{16}$)	32.00	31.75($1\frac{1}{4}$)	1	38.100	2	51 000	81 500	5 200	8 300
	52.388($2\frac{1}{16}$)	25.65	25.40(1)	1.5	38.100	0.5	41 000	61 000	4 150	6 250
30.162($1\frac{3}{16}$)	52.388($2\frac{1}{16}$)	25.65	25.40(1)	1.5	38.100	1	51 000	81 500	5 200	8 300
	55.562($2\frac{3}{16}$)	25.65	25.40(1)	1.5	41.275	0.5	43 500	68 000	4 450	6 950
31.750($1\frac{1}{4}$)	55.562($2\frac{3}{16}$)	32.00	31.75($1\frac{1}{4}$)	1.5	41.275	1	54 500	90 500	5 550	9 250
	55.562($2\frac{3}{16}$)	32.00	31.75($1\frac{1}{4}$)	1.5	41.275	0.5	54 500	90 500	5 550	9 250
33.338($1\frac{5}{16}$)	58.738($2\frac{5}{16}$)	25.65	25.40(1)	1.5	44.450	0.5	44 500	72 000	4 550	7 350
	58.738($2\frac{5}{16}$)	32.00	31.75($1\frac{1}{4}$)	1.5	44.450	1	55 500	95 500	5 700	9 750

Note 1) Allowable minimum chamfer dimension r . 2) Allowable axial stroking value of inner ring against outer ring.

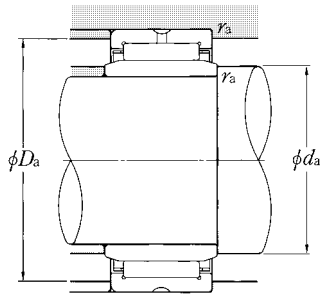

Limiting speeds		Bearing numbers	Abutment dimensions			Mass kg (approx.)
r/min grease	oil		d_a min	mm D_a max	r_{as} max	
17 000	25 000	MR101812+MI-061012	13.5	24.5	0.6	0.069
17 000	25 000	MR101816+MI-061016	13.5	24.5	0.6	0.093
14 000	21 000	MR122012+MI-081212	17.5	26.5	1	0.079
14 000	21 000	MR122016+MI-081216	17.5	26.5	1	0.105
12 000	18 000	MR142212+MI-101412	21	30	1	0.086
12 000	18 000	MR142216+MI-101416	21	30	1	0.118
12 000	18 000	MR142212+MI-111412	21	30	1	0.079
11 000	16 000	MR162412+MI-121612	24	33	1	0.102
11 000	16 000	MR162416+MI-121616	24	33	1	0.136
11 000	16 000	MR162416+MI-131616	24	33	1	0.125
9 500	14 000	MR182616+MI-141816	27	36.5	1	0.152
9 500	14 000	MR182620+MI-141820	27	36.5	1	0.193
9 500	14 000	MR182616+MI-151816	27	36.5	1	0.139
9 500	14 000	MR182620+MI-151820	27	36.5	1	0.176
8 500	13 000	MR202816+MI-162016	30.5	39.5	1	0.161
8 500	13 000	MR202820+MI-162020	30.5	39.5	1	0.201
7 500	11 000	MR223016+MI-182216	33.5	42.5	1	0.181
7 500	11 000	MR223020+MI-182220	33.5	42.5	1	0.229
7 500	11 000	MR243320+MI-192420	35	46	1.5	0.286
7 500	11 000	MR243316+MI-202416	37	46	1.5	0.230
7 500	11 000	MR243320+MI-202420	37	46	1.5	0.285
6 500	9 500	MR263516+MI-212616	40	49	1.5	0.257
6 500	9 500	MR263520+MI-212620	40	49	1.5	0.325
6 500	9 500	MR263520+MI-222620	40	49	1.5	0.286
6 000	9 000	MR283716+MI-222816	41.5	52	1.5	0.294
6 000	9 000	MR283720+MI-222820	41.5	52	1.5	0.364

Inch series
With inner ring

Type MR + MI

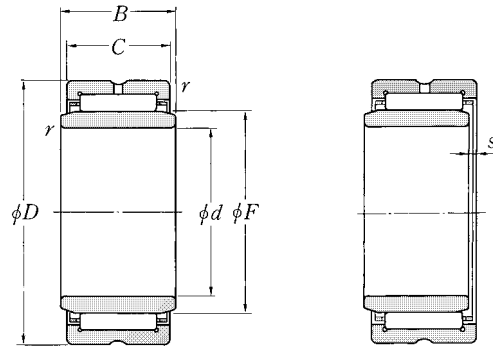

d 36.512~66.675mm

d	Boundary dimensions						Basic load ratings			
	D	B	C	$r_{s\ min}^{1)}$	F	$s^{2)}$	dynamic N	static N	dynamic kgf	static kgf
36.512(1 7/16)	58.738(2 5/16)	25.65	25.40(1)	1.5	44.450	0.5	44 500	72 000	4 550	7 350
	58.738(2 5/16)	32.00	31.75(1 1/4)	1.5	44.450	0.5	55 500	95 500	5 700	9 750
38.100(1 1/2)	58.738(2 5/16)	25.65	25.40(1)	1.5	44.450	0.5	44 500	72 000	4 550	7 350
	58.738(2 5/16)	32.00	31.75(1 1/4)	1.5	44.450	0.5	55 500	95 500	5 700	9 750
39.688(1 9/16)	65.088(2 9/16)	32.00	31.75(1 1/4)	1.5	50.800	0.5	62 000	114 000	6 300	11 700
	65.088(2 9/16)	32.00	31.75(1 1/4)	1.5	50.800	0.5	62 000	114 000	6 300	11 700
41.275(1 5/8)	61.912(2 7/16)	32.00	31.75(1 1/4)	1.5	47.625	1	59 000	105 000	6 000	10 700
	65.088(2 9/16)	32.00	31.75(1 1/4)	1.5	50.800	0.5	62 000	114 000	6 300	11 700
42.682(1 11/16)	65.088(2 9/16)	25.65	25.40(1)	1.5	50.800	0.5	49 500	86 000	5 050	8 800
	65.088(2 9/16)	32.00	31.75(1 1/4)	1.5	50.800	0.5	62 000	114 000	6 300	11 700
44.450(1 3/4)	76.200(3)	38.35	38.10(1 1/2)	1.5	57.150	3.5	83 500	142 000	8 500	14 500
	76.200(3)	44.70	44.45(1 3/4)	1.5	57.150	3.5	97 000	173 000	9 850	17 600
49.212(1 15/16)	82.550(3 1/4)	38.35	38.10(1 1/2)	2	63.500	1.5	88 000	158 000	8 950	16 100
	82.550(3 1/4)	44.70	44.45(1 3/4)	2	63.500	2	102 000	191 000	10 400	19 500
50.800(2)	82.550(3 1/4)	38.35	25.40(1)	2	63.500	2.5	88 000	158 000	8 950	16 100
	82.550(3 1/4)	44.70	44.45(1 3/4)	2	63.500	3	102 000	191 000	10 400	19 500
55.562(2 3/16)	88.900(3 1/2)	44.70	44.45(1 3/4)	2	69.850	1.5	107 000	209 000	10 900	21 300
	88.900(3 1/2)	25.65	25.40(1)	2	69.850	0.5	66 000	112 000	6 700	11 400
57.150(2 1/4)	88.900(3 1/2)	38.35	38.10(1 1/2)	2	69.850	2.5	92 000	173 000	9 400	17 600
	88.900(3 1/2)	44.70	44.45(1 3/4)	2	69.850	3	107 000	209 000	10 900	21 300
60.325(2 3/8)	95.250(3 3/4)	44.70	44.45(1 3/4)	2	76.200	1.5	112 000	227 000	11 400	23 200
	95.250(3 3/4)	38.35	38.10(1 1/2)	2	76.200	2.5	96 000	188 000	9 800	19 100
63.500(2 1/2)	95.250(3 3/4)	44.70	44.45(1 3/4)	2	76.200	3	112 000	227 000	11 400	23 200
	107.950(4 1/4)	44.70	44.45(1 3/4)	2	82.550	3	134 000	240 000	13 600	24 500
66.675(2 5/8)	107.950(4 1/4)	51.05	50.80(2)	2	82.550	5.5	146 000	268 000	14 900	27 400

Note 1) Allowable minimum chamfer dimension r . 2) Allowable axial stroking value of inner ring against outer ring.

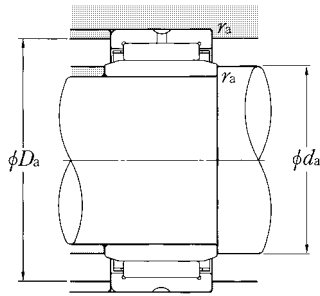

Limiting speeds		Bearing numbers	Abutment dimensions			Mass kg (approx.)
r/min grease	oil		d_a min	mm D_a max	r_{as} max	
6 000	9 000	MR283716 + MI-232816	43	52	1.5	0.264
6 000	9 000	MR283720 + MI-232820	43	52	1.5	0.330
6 000	9 000	MR283716 + MI-242816	43	52	1.5	0.246
6 000	9 000	MR283720 + MI-242820	43	52	1.5	0.307
5 500	8 000	MR324120 + MI-243220	44.5	58.5	1.5	0.448
5 500	8 500	MR303920 + MI-253020	46.5	55.5	1.5	0.368
5 500	8 000	MR324120 + MI-253220	46	58.5	1.5	0.424
5 500	8 000	MR324116 + MI-263216	48	58.5	1.5	0.317
5 500	8 000	MR324120 + MI-263220	48	58.5	1.5	0.402
5 500	8 000	MR324116 + MI-273216	49.5	58.5	1.5	0.300
5 500	8 000	MR324120 + MI-273220	49.5	58.5	1.5	0.373
4 700	7 000	MR364824 + MI-283624	51	69.5	1.5	0.732
4 700	7 000	MR364828 + MI-283628	51	69.5	1.5	0.853
4 300	6 500	MR405224 + MI-314024	56	74.5	2	0.848
4 300	6 500	MR405228 + MI-314028	56	74.5	2	0.975
4 300	6 500	MR405224 + MI-324024	59	74.5	2	0.812
4 300	6 500	MR405228 + MI-324028	59	74.5	2	0.923
3 700	5 500	MR445628 + MI-354428	63.5	81	2	1.07
3 700	5 500	MR445616 + MI-364416	65	81	2	0.594
3 700	5 500	MR445624 + MI-364424	65	81	2	0.884
3 700	5 500	MR445628 + MI-364428	65	81	2	1.02
3 300	5 000	MR486028 + MI-384828	68	87	2	1.25
3 300	5 000	MR486024 + MI-404824	71.5	87	2	0.978
3 300	5 000	MR486028 + MI-404828	71.5	87	2	1.14
3 300	5 000	MR526828 + MI-425228	74.5	100	2	1.67
3 300	5 000	MR526832 + MI-425232	74.5	100	2	1.92

Inch series With inner ring

Type MR + MI

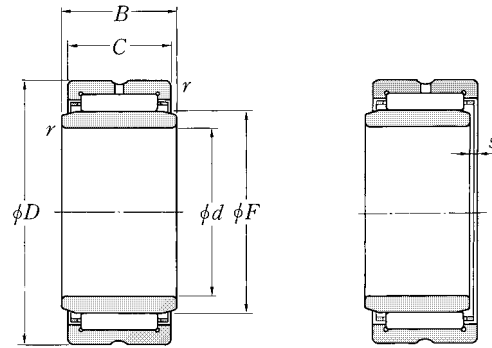

d 69.850~127.000mm

Boundary dimensions							Basic load ratings			
mm ($\frac{1}{25.4}$ mm)							dynamic	static	dynamic	static
d	D	B	C	r 's min ¹⁾	F	s ²⁾	C_r	C_{or}	C_r	C_{or}
							N		kgf	
69.850(2 $\frac{3}{4}$)	107.950(4 $\frac{1}{4}$)	44.70	44.45(1 $\frac{3}{4}$)	2	82.550	1.5	134 000	240 000	13 600	24 500
	107.950(4 $\frac{1}{4}$)	51.05	50.80(2)	2	82.550	3	146 000	268 000	14 900	27 400
74.612(2 $\frac{15}{16}$)	114.300(4 $\frac{1}{2}$)	51.05	50.80(2)	2	88.900	3	154 000	295 000	15 700	30 000
76.200(3)	114.300(4 $\frac{1}{2}$)	44.70	44.45(1 $\frac{3}{4}$)	2	88.900	3	141 000	264 000	14 400	26 900
	114.300(4 $\frac{1}{2}$)	51.05	50.80(2)	2	88.900	5.5	154 000	295 000	15 700	30 000
79.375(3 $\frac{1}{8}$)	120.650(4 $\frac{3}{4}$)	51.05	50.80(2)	2.5	95.250	5.5	162 000	320 000	16 500	32 500
82.550(3 $\frac{1}{4}$)	120.650(4 $\frac{3}{4}$)	51.05	50.80(2)	2.5	95.250	2.5	162 000	320 000	16 500	32 500
	127.000(5)	51.05	50.80(2)	2.5	101.600	2.5	169 000	345 000	17 200	35 500
85.725(3 $\frac{3}{8}$)	127.000(5)	51.05	50.80(2)	2.5	101.600	4.5	169 000	345 000	17 200	35 500
88.900(3 $\frac{1}{2}$)	127.000(5)	51.05	50.80(2)	2.5	101.600	2.5	169 000	345 000	17 200	35 500
	133.350(5 $\frac{1}{4}$)	51.05	50.80(2)	2.5	107.950	2.5	172 000	360 000	17 500	37 000
92.075(3 $\frac{5}{8}$)	133.350(5 $\frac{1}{4}$)	51.05	50.80(2)	2.5	107.950	4.5	172 000	360 000	17 500	37 000
	133.350(5 $\frac{1}{4}$)	51.05	50.80(2)	2.5	107.950	2.5	172 000	360 000	17 500	37 000
95.250(3 $\frac{3}{4}$)	152.400(6)	57.40	57.15(2 $\frac{1}{4}$)	2.5	114.300	3	238 000	435 000	24 300	44 500
	152.400(6)	63.88	63.50(2 $\frac{1}{2}$)	2.5	114.300	4	260 000	485 000	26 500	49 500
98.425(3 $\frac{7}{8}$)	152.400(6)	57.40	57.15(2 $\frac{1}{4}$)	2.5	114.300	5.5	238 000	435 000	24 300	44 500
	152.400(6)	63.88	63.50(2 $\frac{1}{2}$)	2.5	114.300	7	260 000	485 000	26 500	49 500
101.600(4)	165.100(6 $\frac{1}{2}$)	51.05	50.80(2)	2.5	127.000	2.5	227 000	425 000	23 200	43 000
	165.100(6 $\frac{1}{2}$)	57.40	57.15(2 $\frac{1}{4}$)	2.5	127.000	5.5	250 000	480 000	25 500	49 000
	165.100(6 $\frac{1}{2}$)	63.88	57.15(2 $\frac{1}{4}$)	2.5	127.000	7	273 000	535 000	27 800	54 500
107.950(4 $\frac{1}{4}$)	165.100(6 $\frac{1}{2}$)	57.40	57.15(2 $\frac{1}{4}$)	2.5	127.000	3	250 000	480 000	25 500	49 000
114.300(4 $\frac{1}{2}$)	177.800(7)	63.88	63.50(2 $\frac{1}{2}$)	2.5	139.700	5.5	285 000	585 000	29 100	59 500
	177.800(7)	76.58	76.20(3)	2.5	139.700	7	345 000	740 000	35 000	75 500
120.650(4 $\frac{3}{4}$)	184.150(7 $\frac{1}{4}$)	82.55	76.20(3)	3	146.050	3	360 000	775 000	36 500	79 000
127.000(5)	190.500(7 $\frac{1}{2}$)	63.88	63.50(2 $\frac{1}{2}$)	3	152.400	7	310 000	630 000	31 500	64 000
	190.500(7 $\frac{1}{2}$)	76.58	76.20(3)	3	152.400	5.5	375 000	800 000	38 000	81 500

Note 1) Allowable minimum chamfer dimension r . 2) Allowable axial stroking value of inner ring against outer ring.

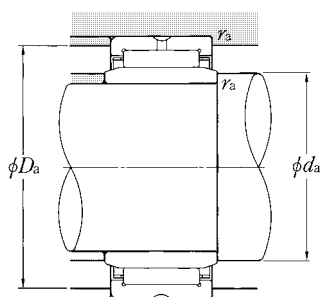

Limiting speeds		Bearing numbers	Abutment dimensions			Mass kg (approx.)
grease	oil		d_a min	mm D_a max	r_{as} max	
3 300	5 000	MR526828 + MI-445228	78	100	2	1.55
3 300	5 000	MR526832 + MI-445232	78	100	2	1.77
3 000	4 500	MR567232 + MI-475632	83	106.5	2	2.00
3 000	4 500	MR567228 + MI-485628	84	106.5	2	1.65
3 000	4 500	MR567232 + MI-485632	84	106.5	2	1.92
2 800	4 200	MR607632 + MI-506032	88.5	111.5	2.5	2.15
2 800	4 200	MR607632 + MI-526032	91.5	111.5	2.5	1.99
2 600	3 900	MR648032 + MI-526432	91.5	118	2.5	2.39
2 600	3 900	MR648032 + MI-546432	94.5	118	2.5	2.22
2 600	3 900	MR648032 + MI-566432	98	118	2.5	2.05
2 500	3 700	MR688432 + MI-566832	98	124.5	2.5	2.53
2 500	3 700	MR688432 + MI-586832	101	124.5	2.5	2.36
2 500	3 700	MR688432 + MI-606832	104.5	124.5	2.5	2.17
2 300	3 500	MR729636 + MI-607236	104.5	143.5	2.5	4.02
2 300	3 500	MR729640 + MI-607240	104.5	143.5	2.5	4.47
2 300	3 500	MR729636 + MI-627236	107.5	143.5	2.5	3.77
2 300	3 500	MR729640 + MI-627240	107.5	143.5	2.5	4.19
2 100	3 100	MR8010432 + MI-648032	110.5	156	2.5	3.60
2 100	3 100	MR8010436 + MI-648036	110.5	156	2.5	4.92
2 100	3 100	MR8010440 + MI-648040	110.5	156	2.5	5.47
2 100	3 100	MR8010436 + MI-688036	117	156	2.5	4.44
1 900	2 900	MR8811240 + MI-728840	123.5	169	2.5	6.04
1 900	2 900	MR8811248 + MI-728848	123.5	169	2.5	7.26
1 800	2 700	MR9211648 + MI-769248	132	172	3	7.48
1 700	2 600	MR9612040 + MI-809640	140	177.5	3	6.54
1 700	2 600	MR9612048 + MI-809648	140	177.5	3	7.84

Inch series
With inner ring

Type MR + MI

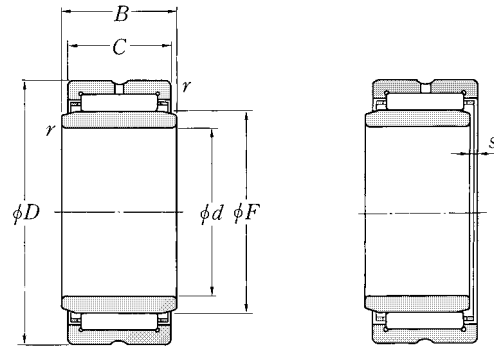

d 139.700~203.200mm

d	Boundary dimensions						Basic load ratings			
	D	B	C	r's min ¹⁾	F	s ²⁾	dynamic N	static	dynamic kgf	static
	mm (1/25.4mm)									
139.700(5 1/2)	203.200(8)	63.88	63.50(2 1/2)	3	165.100	6	325 000	680 000	33 000	69 500
	203.200(8)	76.58	76.20(3)	3	165.100	5.5	390 000	870 000	39 500	88 500
152.400(6)	231.775(9 1/8)	76.58	76.20(3)	3	184.150	8.5	435 000	915 000	44 500	93 000
165.100(6 1/2)	244.475(9 5/8)	76.58	76.20(3)	3	196.850	8.5	455 000	990 000	46 500	101 000
177.800(7)	257.175(10 1/8)	76.58	76.20(3)	3	209.550	8.5	475 000	1 060 000	48 500	109 000
190.500(7 1/2)	269.875(10 5/8)	76.58	76.20(3)	4	222.250	7	495 000	1 140 000	50 500	116 000
203.200(8)	282.575(11 1/8)	76.58	76.20(3)	4	234.950	7	510 000	1 210 000	52 000	124 000

Note 1) Allowable minimum chamfer dimension *r*. 2) Allowable axial stroking value of inner ring against outer ring.

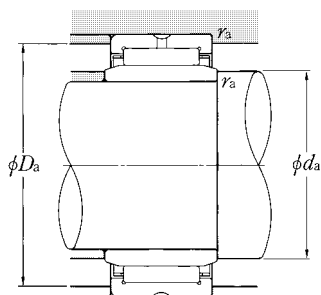

Limiting speeds		Bearing numbers	Abutment dimensions			Mass kg (approx.)
grease	oil		d_a min	mm D_a max	r_{as} max	
1 600	2 400	MR10412840+MI-8810440	152.5	190	3	6.86
1 600	2 400	MR10412848+MI-8810448	152.5	190	3	8.22
1 500	2 200	MR11614648+MI-9611648	165.5	219	3	12.2
1 300	2 000	MR12415448+MI-10412448	178	231.5	3	13.1
1 300	1 900	MR13216248+MI-11213248	191	244	3	14.0
1 200	1 800	MR14017048+MI-12014048	206.5	254	4	15.0
1 100	1 700	MR14817848+MI-12814848	219	266.5	4	15.8

Without inner ring

Type RNA49·L
Type RNA49·LL

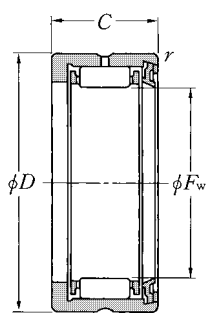

Type RNA49·L
(With single seal)

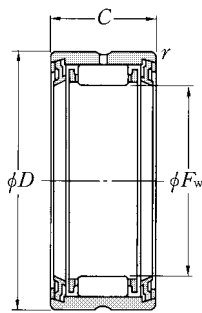

Type RNA49·LL
(With double seal)

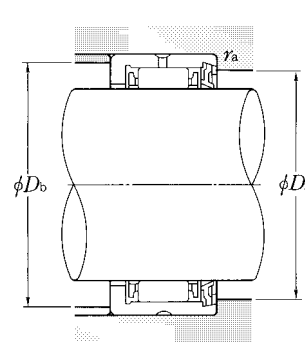

F_w 14~58mm

Boundary dimensions				Basic load ratings				Limiting speeds r/min grease	Bearing numbers		Abutment dimensions			Mass kg (approx.)	
mm				dynamic	static	dynamic	static		Type	Type	D_a	D_b	r_{as}		
F_w	D	C	$r_{s \min}^{1)}$	C_r	C_{or}	C_r	C_{or}	RNA49·L	RNA49·LL	max	max	max			
14	$\begin{smallmatrix} +0.027 \\ +0.016 \end{smallmatrix}$	22	13	0.3	7 200	8 500	735	865	10 000	RNA4900L	RNA4900LL	16	20	0.3	0.016
16	$\begin{smallmatrix} +0.027 \\ +0.016 \end{smallmatrix}$	24	13	0.3	7 750	9 700	795	990	10 000	RNA4901L	RNA4901LL	18	22	0.3	0.018
20	$\begin{smallmatrix} +0.033 \\ +0.020 \end{smallmatrix}$	28	13	0.3	8 300	11 200	845	1 150	10 000	RNA4902L	RNA4902LL	22	26	0.3	0.022
22	$\begin{smallmatrix} +0.033 \\ +0.020 \end{smallmatrix}$	30	13	0.3	8 500	11 900	865	1 220	9 000	RNA4903L	RNA4903LL	24	28	0.3	0.022
25	$\begin{smallmatrix} +0.033 \\ +0.020 \end{smallmatrix}$	37	17	0.3	15 200	19 900	1 550	2 030	8 000	RNA4904L	RNA4904LL	28	35	0.3	0.055
30	$\begin{smallmatrix} +0.033 \\ +0.020 \end{smallmatrix}$	42	17	0.3	16 000	22 600	1 640	2 300	6 500	RNA4905L	RNA4905LL	33	40	0.3	0.063
35	$\begin{smallmatrix} +0.041 \\ +0.025 \end{smallmatrix}$	47	17	0.3	18 000	27 400	1 830	2 800	5 500	RNA4906L	RNA4906LL	38	45	0.3	0.072
42	$\begin{smallmatrix} +0.041 \\ +0.025 \end{smallmatrix}$	55	20	0.6	22 700	39 500	2 320	4 000	4 800	RNA4907L	RNA4907LL	45	51	0.6	0.113
48	$\begin{smallmatrix} +0.041 \\ +0.025 \end{smallmatrix}$	62	22	0.6	27 800	53 500	2 830	5 450	4 200	RNA4908L	RNA4908LL	51	58	0.6	0.154
52	$\begin{smallmatrix} +0.049 \\ +0.030 \end{smallmatrix}$	68	22	0.6	28 600	57 000	2 920	5 800	3 800	RNA4909L	RNA4909LL	55	64	0.6	0.157
58	$\begin{smallmatrix} +0.049 \\ +0.030 \end{smallmatrix}$	72	22	0.6	30 500	64 000	3 100	6 500	3 400	RNA4910L	RNA4910LL	61	68	0.6	0.160

Note 1) Allowable minimum chamfer dimension r .

With inner ring

Type NA49··L

Type NA49··LL

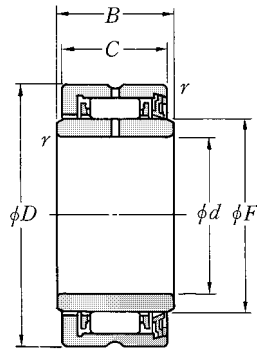

Type NA49··L
(With single seal)

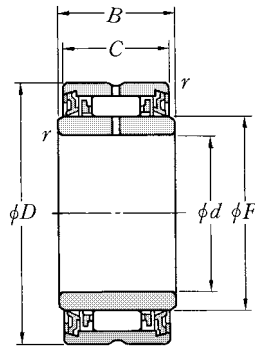

Type NA49··LL
(With double seal)

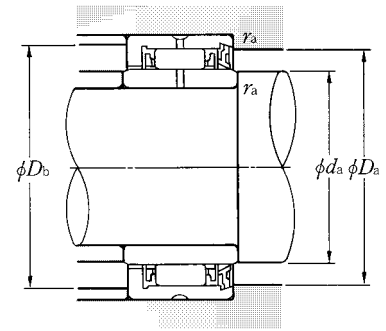

d 10~50mm

Boundary dimensions						Basic load ratings				Limiting speeds r/min grease	Bearing numbers		Abutment dimensions				Mass kg (approx.)
mm						dynamic	static	dynamic	static		Type	Type	d_a	D_a	D_b	r_{as}	
d	D	B	C	$r_{s \min}^1$	F	C_r	C_{or}	C_r	C_{or}		NA49··L	RNA49··LL	min	max	max	max	
10	22	14	13	0.3	14	7 200	8 500	735	865	10 000	NA4900L	NA4900LL	12	16	20	0.3	0.025
12	24	14	13	0.3	16	7 750	9 700	795	990	10 000	NA4901L	NA4901LL	14	18	22	0.3	0.028
15	28	14	13	0.3	20	8 300	11 200	845	1 150	10 000	NA4902L	NA4902LL	17	22	26	0.3	0.036
17	30	14	13	0.3	22	8 500	11 900	865	1 220	9 000	NA4903L	NA4903LL	19	24	28	0.3	0.039
20	37	18	17	0.3	25	15 200	19 900	1 550	2 030	8 000	NA4904L	NA4904LL	22	28	35	0.3	0.080
25	42	18	17	0.3	30	16 000	22 600	1 640	2 300	6 500	NA4905L	NA4905LL	27	33	40	0.3	0.093
30	47	18	17	0.3	35	18 000	27 400	1 830	2 800	5 500	NA4906L	NA4906LL	32	38	45	0.3	0.107
35	55	21	20	0.6	42	22 700	39 500	2 320	4 000	4 800	NA4907L	NA4907LL	39	45	51	0.6	0.175
40	62	23	22	0.6	48	27 800	53 500	2 830	5 450	4 200	NA4908L	NA4908LL	44	51	58	0.6	0.252
45	68	23	22	0.6	52	28 600	57 000	2 920	5 800	3 800	NA4909L	NA4909LL	49	55	64	0.6	0.290
50	72	23	22	0.6	58	30 500	64 000	3 100	6 500	3 400	NA4910L	NA4910LL	54	61	68	0.6	0.295

Note 1) Allowable minimum chamfer dimension r .